



### Order example

**MCHC-20-N**

MODEL

TUBE I.D.

TYPE

	Standard
Blank	
N	

### Installation of sensor switch

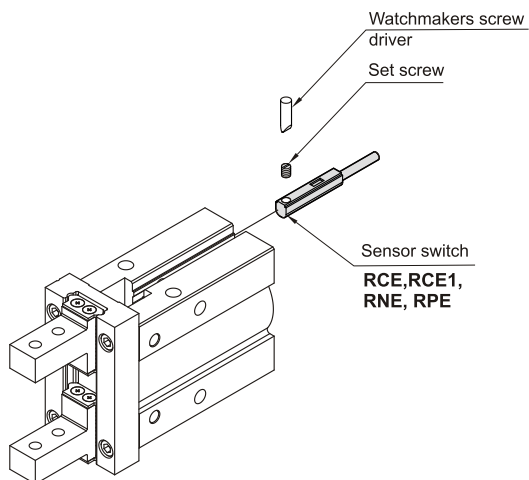

### Features

- Integral linear guide used for high rigidity and high precision.
- The material of finger is martensitic stainless steel.
- Grooves on the body for sensor switch to be inserted into.
- Standard with magnet.

### Specification

Model	MCHC	
Acting type	Double acting	
Tube I.D. (mm)	10	16, 20, 25
Port size	M3 × 0.5	M5 × 0.8
Medium	Air	
Operating pressure range	0.2~0.7 MPa	0.1~0.7 MPa
Ambient temperature	-10~+60°C (No freezing)	
Repeatability	± 0.01 mm	
Max. frequency	180 cycles / min	
Lubricator	Not required	
Sensor switch (※)	RCE / RCE1: Reed switch,	
	RNE: NPN, RPE: PNP	
Weight (g)	55	125, 250, 460

※ RCE, RCE1 specification, please refer to page V-09.

### Gripping force

Tube I.D. (mm)	Gripping force <sup>(1)</sup>		Opening closing stroke (Both sides) (mm)
	Gripping force per finger effective value N (kgf)		
	External	Internal	
10	9.8 (1)	17 (1.7)	4
16	30 (3.1)	40 (4.1)	6
20	42 (4.3)	66 (6.7)	10
25	65 (6.6)	104 (10.6)	14

Note 1) Values based on pressure of 0.5 MPa, gripping point L=20mm, at center of stroke.

### Length of gripping point

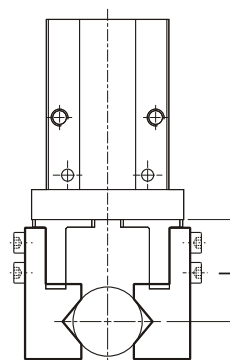

## PARALLEL GRIPPERS

Mindman

$\phi 10$

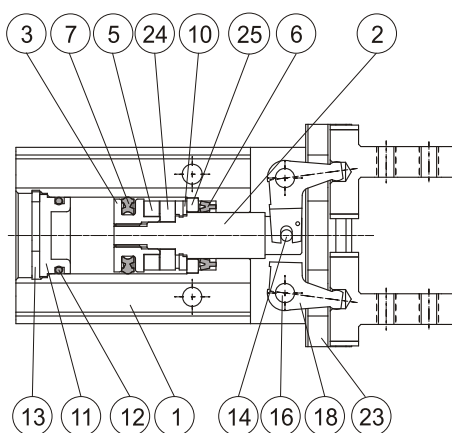
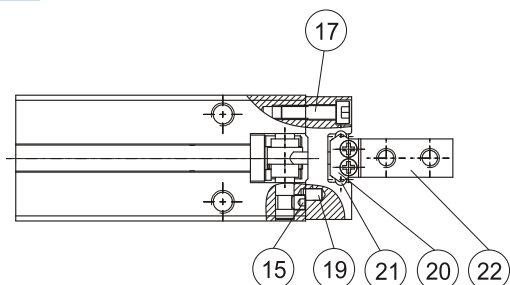

$\phi 16 \sim \phi 25$

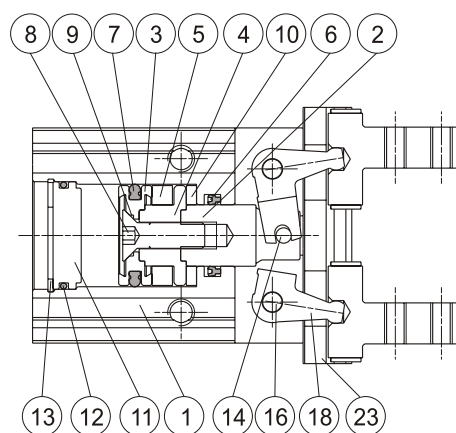
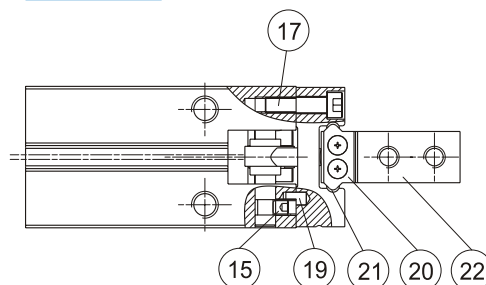

## Material

No.	Tube I.D.				Q'y	Repair kits (inclusion)
	10	16	20	25		
1	Aluminum alloy				1	
2	Stainless steel				1	
3	Aluminum alloy				1	
4	—	Aluminum alloy			1	
5	Magnet material				1	
6	NBR				1	●
7	NBR				1	●
8	—	Stainless steel			1	
9	—	NBR			1	●
10	PU				1	●
11	Aluminum alloy				1	
12	NBR				1	●
13	Stainless steel				1	
14	Carbon steel				1	
15	Carbon steel				4	
16	Carbon steel				2	
17	Stainless steel				4	

No.	Tube I.D.				Q'y	Repair kits (inclusion)
	10	16	20	25		
18	Stainless steel				2	
19	Carbon steel				2	
20	Stainless steel				4	
21	Stainless steel				24	
22	Stainless steel				2	
23	Stainless steel				1	
24	※1	—			1	
25	※1	—			1	

※1 : Stainless steel

## Order example of repair kits

Tube I.D.	Repair kits
$\phi 10$	<b>PS-MCHC-10</b>
$\phi 16$	<b>PS-MCHC-16</b>
$\phi 20$	<b>PS-MCHC-20</b>
$\phi 25$	<b>PS-MCHC-25</b>

## PARALLEL GRIPPERS

### Model selection

Please select your model according to the weight of workpiece

- Although conditions differ according to the work piece shape and the coefficient of friction between the attachments and the workpiece, select a model that can provide a gripping force of 10 to 20 times the workpiece weight, or more.
- If high acceleration, deceleration or impact forces are encountered during motion, a further margin of safety should be considered.

When gripping a workpiece as in the figure as shown above:

**F** : Gripping force (N)

$\mu$  : Coefficient of friction between the attachments and the workpiece

**m** : Workpiece mass (kg)

**g** : Gravitational acceleration (=9.8m/s<sup>2</sup>)

**mg** : Workpiece weight (N)

the conditions under which the workpiece will not drop are,

$$2 \times \mu F > mg$$

Number of fingers

Therefore,

$$F > \frac{mg}{2 \times \mu}$$

With "a" representing the extra margin, "F" is determined by the following formula:

$$F = \frac{mg}{2 \times \mu} \times a$$

The "10 to 20 times or more of the workpiece weight" is calculated with a safety margin of a=4, which allows for impacts that occur during normal transportation, etc °

$\mu = 0.2$	$\mu = 0.1$
$F = \frac{mg}{2 \times 0.2} \times 4$ $= 10 \times mg$	$F = \frac{mg}{2 \times 0.1} \times 4$ $= 20 \times mg$
↓	↓
10 × workpiece weight	20 × workpiece weight

- ※1. Even in cases where the coefficient of friction is greater than  $\mu = 0.2$ , for reasons of safety, please select a gripping force which is at least 10 to 20 times greater than the workpiece weight.
- ※2. If high acceleration, deceleration or impact forces are encountered during motion, a further margin of safety should be considered.

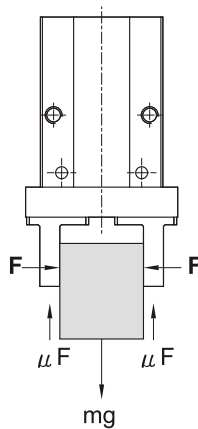

### Confirmation of external force on fingers

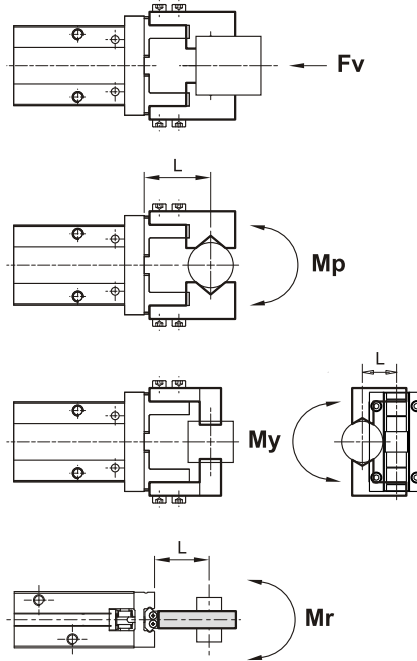

L: distance to the point at which the load is applied (mm)

Tube I.D. (mm)	Allowable vertical load Fv(N)	Maximum allowable moment		
		Pitch moment Mp(N·m)	Yaw moment My(N·m)	Roll moment Mr(N·m)
10	58	0.26	0.26	0.53
16	98	0.68	0.68	1.36
20	147	1.32	1.32	2.65
25	255	1.94	1.94	3.88

※ Values for load and moment in the table indicate static values.

### Allowable load calculation

$$\text{Allowable load } F(N) = \frac{M(\text{maximum allowable moment})(N \cdot m)}{L(m)}$$

#### Example

When a static load of f=20N is operating, which applies pitch moment to point L=25mm from the MCHC-16 guide.

$$\text{Allowable load } F(N) = \frac{0.68(N \cdot m)}{25 \times 10^{-3}(m)}$$

$$= 27.2(N)$$

Load f=20(N) < 27.2(N), So can be used.

### Effective gripping force (Double acting)

Indication of effective force :

The effective gripping force shown in the graphs to the right is expressed as F, which is the thrust of one finger, when both fingers and attachments are in full contact with the workpiece as shown in the figure below.

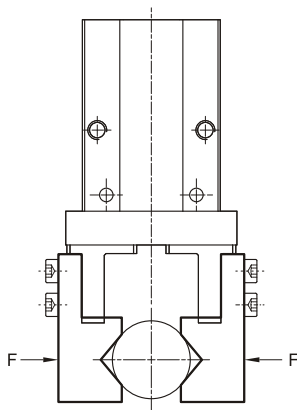

$$1\text{N} = 0.102 \text{ kgf}$$

$$1\text{MPa} = 10.2 \text{ kgf/cm}^2$$

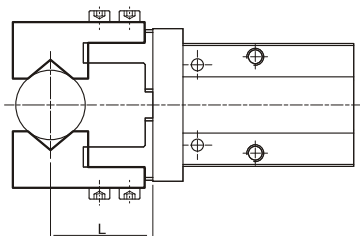

External grip

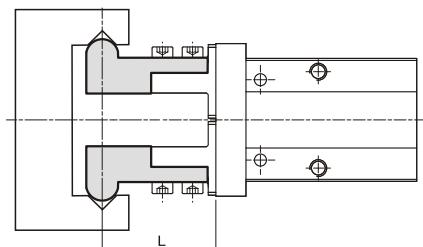

Internal grip

### External gripping force

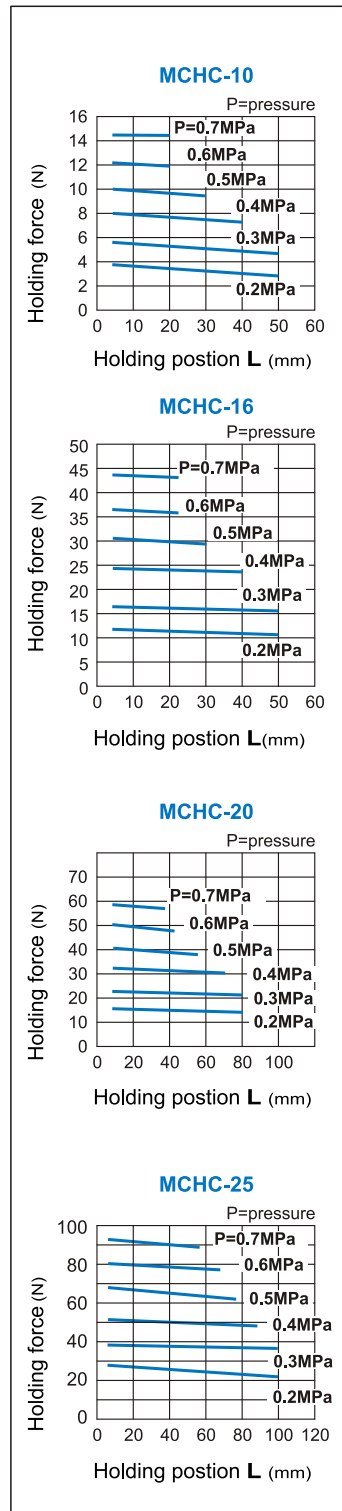

### Internal gripping force

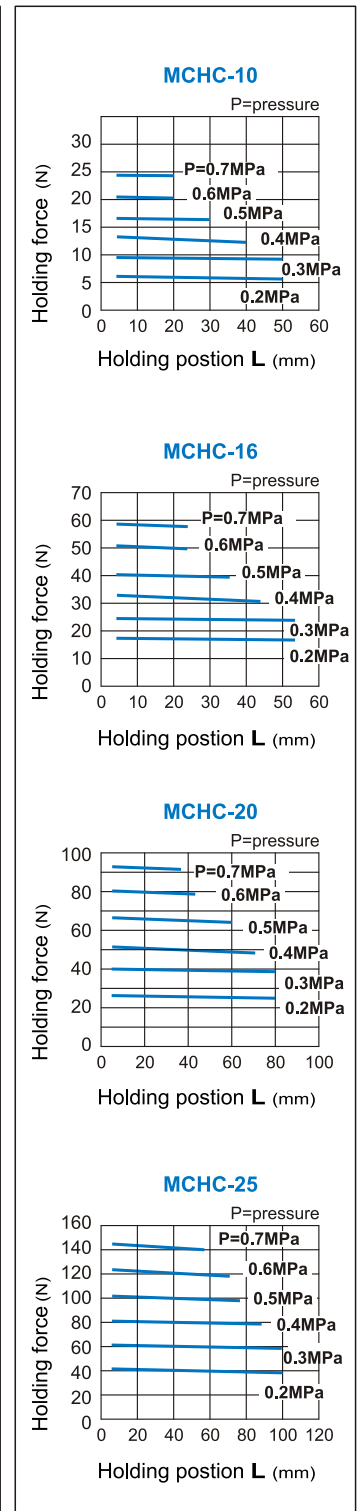

### Confirmation of gripping point

- The air gripper should be operated so that the workpiece gripping point "L" and the amount of overhang "H" stay within the range shown for each operating pressure given in the graphs to the right.
- If the workpiece gripping point goes beyond the range limits, this will have an adverse effect on the life the air gripper.

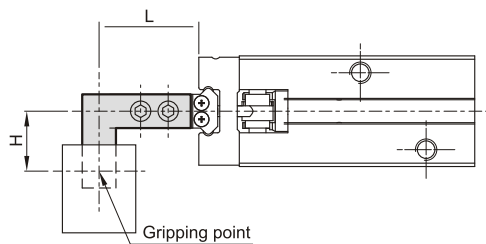
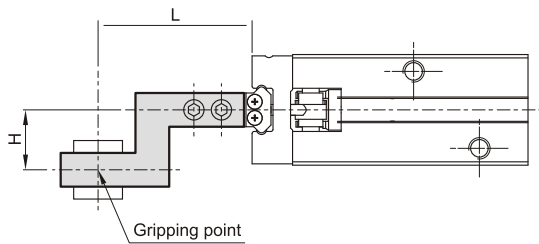

### External gripping force

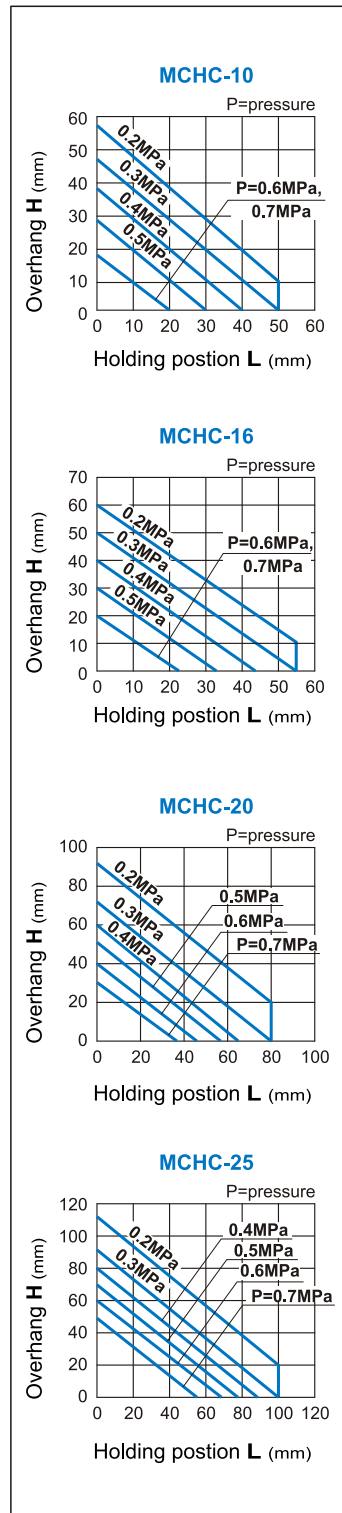

### Internal gripping force

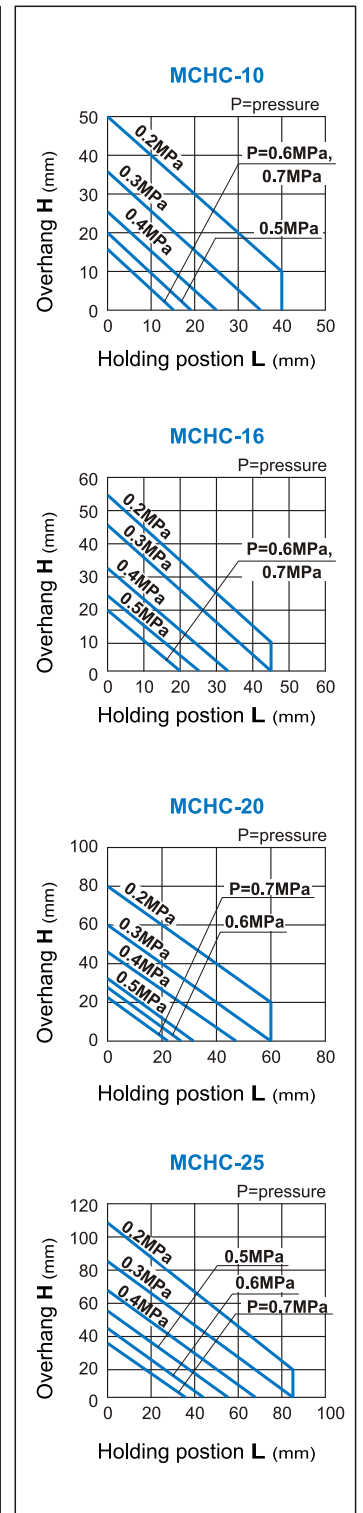

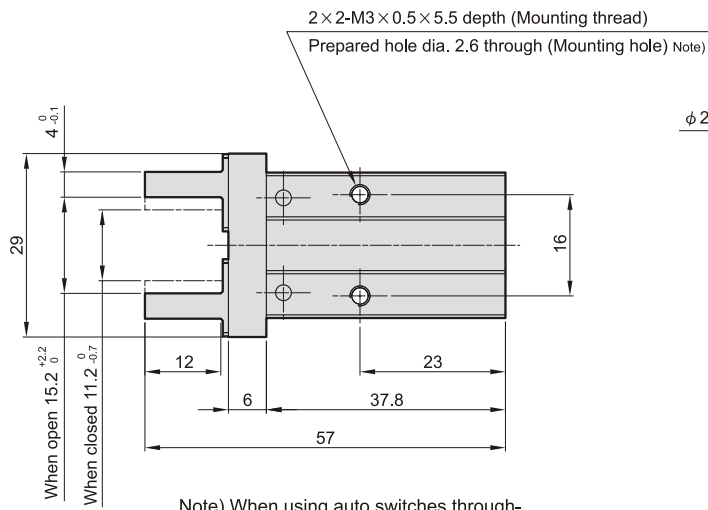
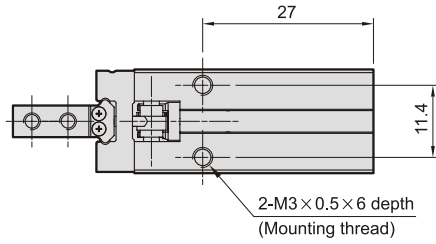

Note) When using auto switches, through-hole mounting is not possible.

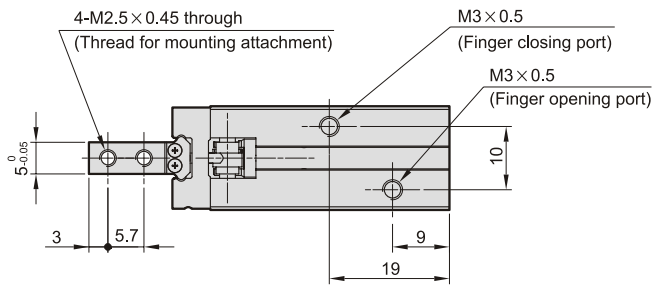
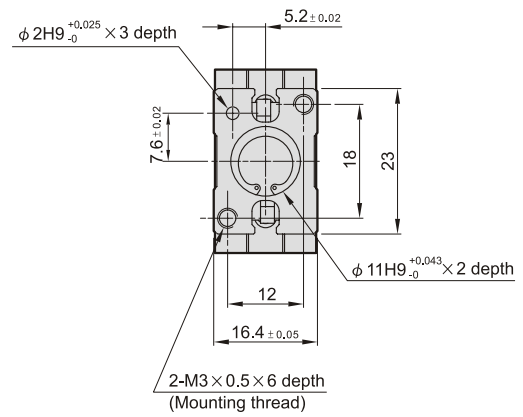

### Finger position / Narrow type

#### MCHC-10-N

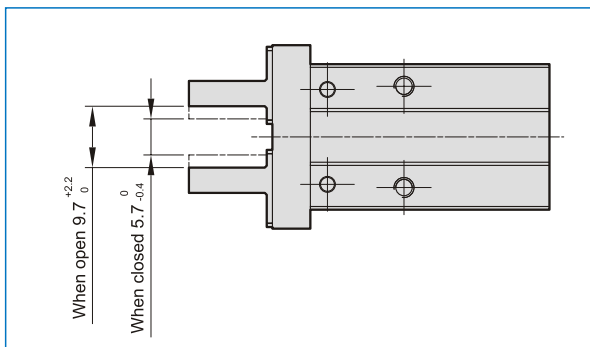

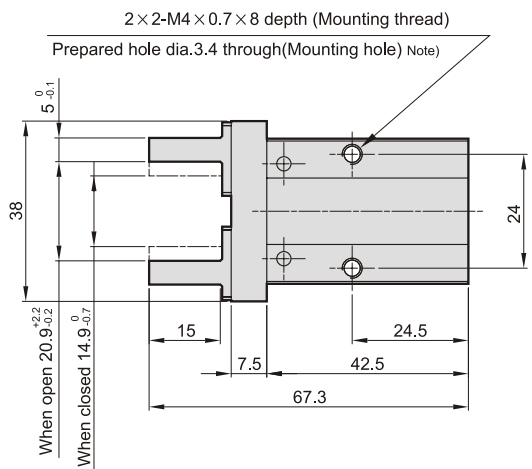
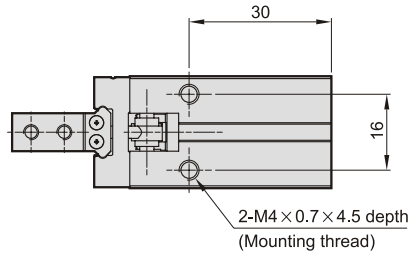

Note) Through-hole mounting is not possible when using the auto switch at the square groove.

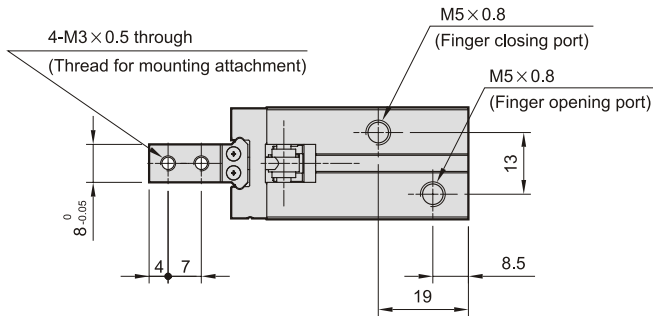
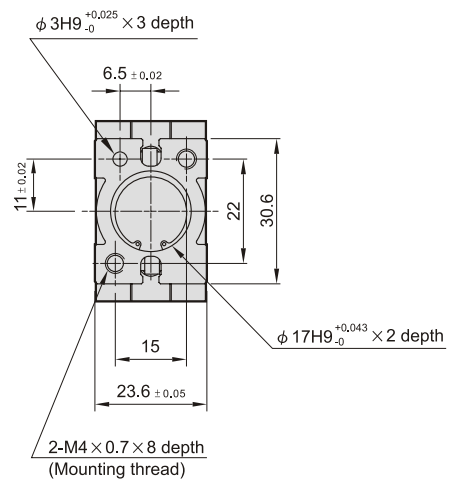

Finger position / Narrow type  
MCHC-16-N

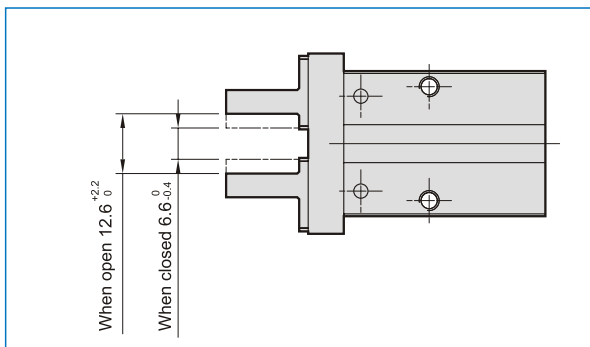

PARALLEL GRIPPERS

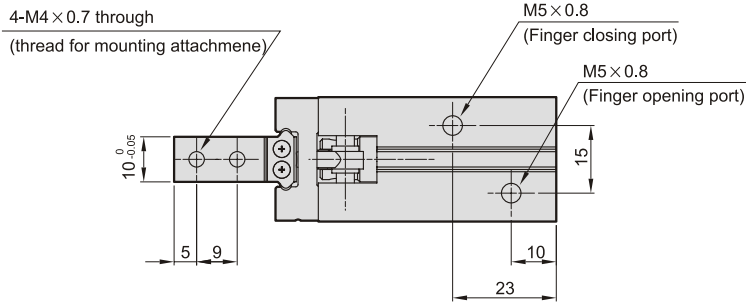
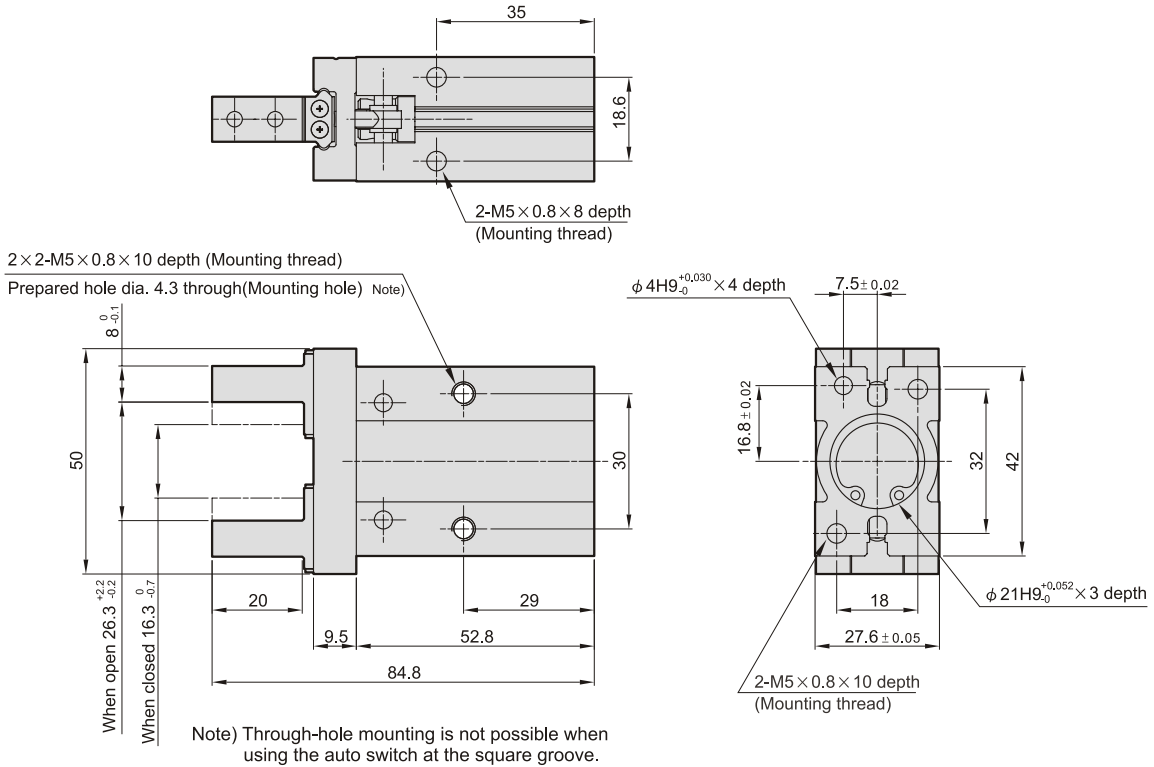

Finger position / Narrow type  
MCHC-20-N

