

## 特殊軸端形狀

### ■ 特殊軸端形狀：

MCQA — 標準訂購代號 — XR02

型號

MCQA  
MCQV2  
MCQV  
MCQI2

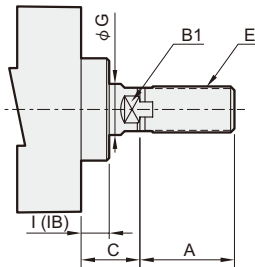

特殊軸端形狀

系列	內徑 (mm)	A	B1	C	E	G	I (IB)
MCQA	40	30	14	21	M14×1.5	16	11
	50	35	17	23	M18×1.5	20	11
	63	35	17	23	M18×1.5	20	11
	80	40	22	31	M22×1.5	25	15
	100	40	27	32	M26×1.5	30	15
	125	45	30	47	M30×1.5	35	32
	150	50	36	47	M30×1.5	40	32
MCQV2 MCQI2	32	22	10	26	M10×1.25	12	20
	40	24	13	30	M12×1.25	16	20.5
	50	32	16	37	M16×1.5	20	28
	63	32	16	37	M16×1.5	20	26
	80	40	21	46	M20×1.5	25	32.5
MCQV	100	40	21	51	M20×1.5	25	37.5
	125	54	27	65	M27×2.0	32	40
	160	72	36	80	M36×2.0	40	55
	200	72	36	95	M36×2.0	40	55

EX: MCQA-11-40-100M-XR02 (A=50, C=35, E=M12×1.25)

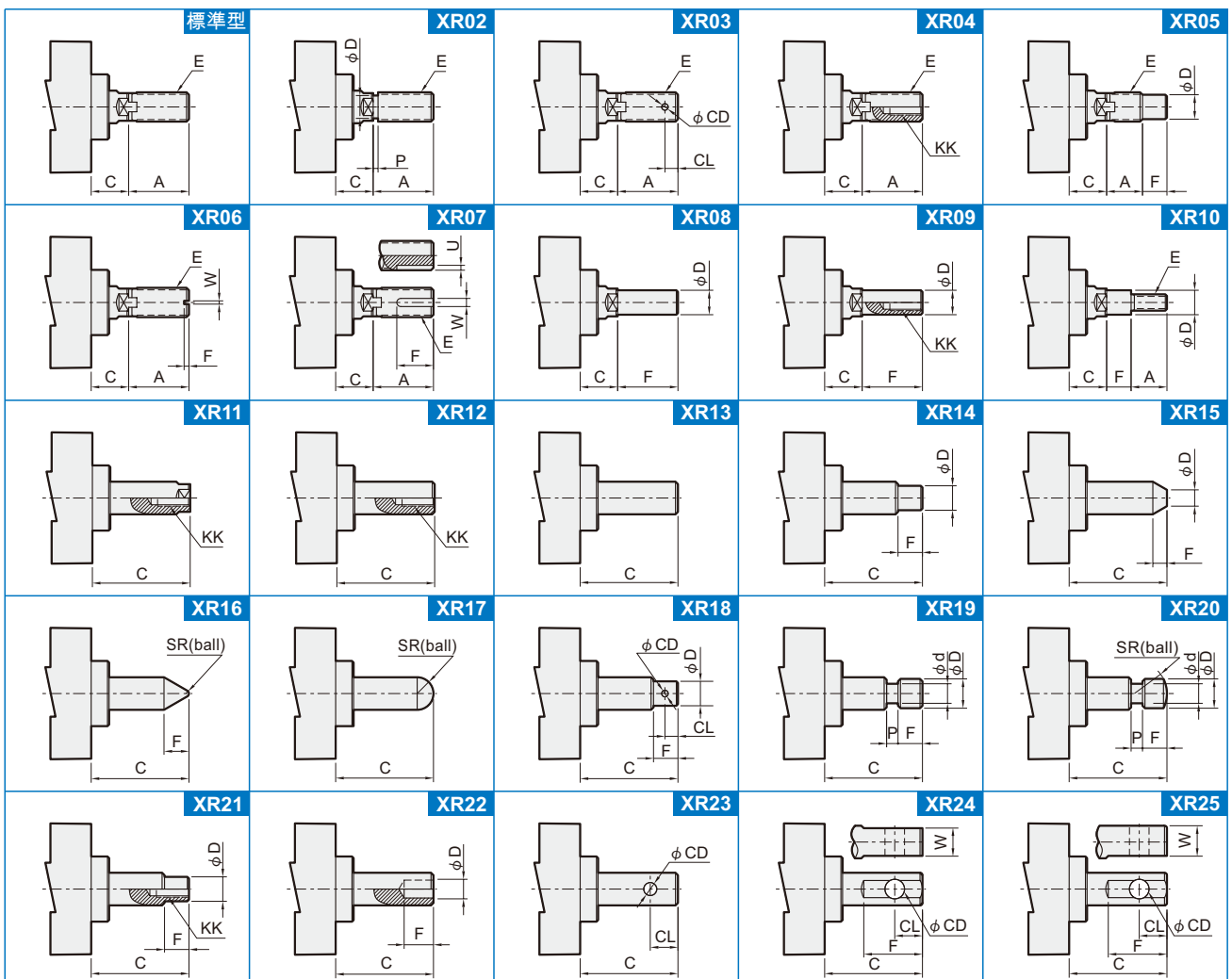

註：部份未標示尺寸，請洽業務人員。

### ■ 特殊軸端形狀：

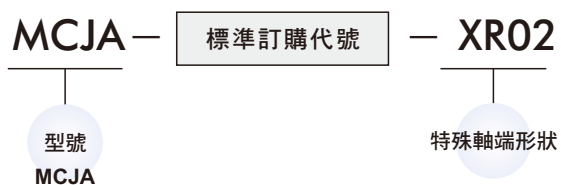

EX: MCJA-11-40-100M-XR02 (H=50, AQ=35, Q=M12×1.25)

#### 11：外牙型

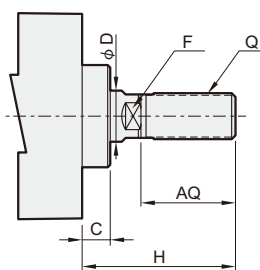

#### 12：內牙型

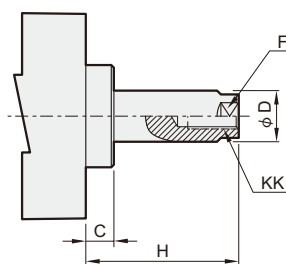

系列	內徑	AQ	C	D	F	H		KK	Q
						11 外牙型	12 內牙型		
MCJA	12	12	1	6	5	17	5	M3×0.5×6 深	M5×0.8
	16	12	1.5	6	5	17.5	5.5	M3×0.5×6 深	M5×0.8
	20	15	1.5	8	6	20.5	5.5	M4×0.7×8 深	M6×1.0
	25	17	2	10	8	23	6	M5×0.8×10 深	M8×1.25
	32	18	3	12	10	25	7	M6×1.0×12 深	M10×1.25
	40	28	3	16	14	35	7	M8×1.25×12 深	M14×1.5
	50	28	4	20	17	37	9	M10×1.5×15 深	M18×1.5
	63	28	4	20	17	37	9	M10×1.5×15 深	M18×1.5
	80	33	5	25	22	44	11	M14×1.5×20 深	M22×1.5
100	38	5	30	27	50	12	M18×1.5×20 深	M26×1.5	

## 特殊軸端形狀

特殊軸端形狀：

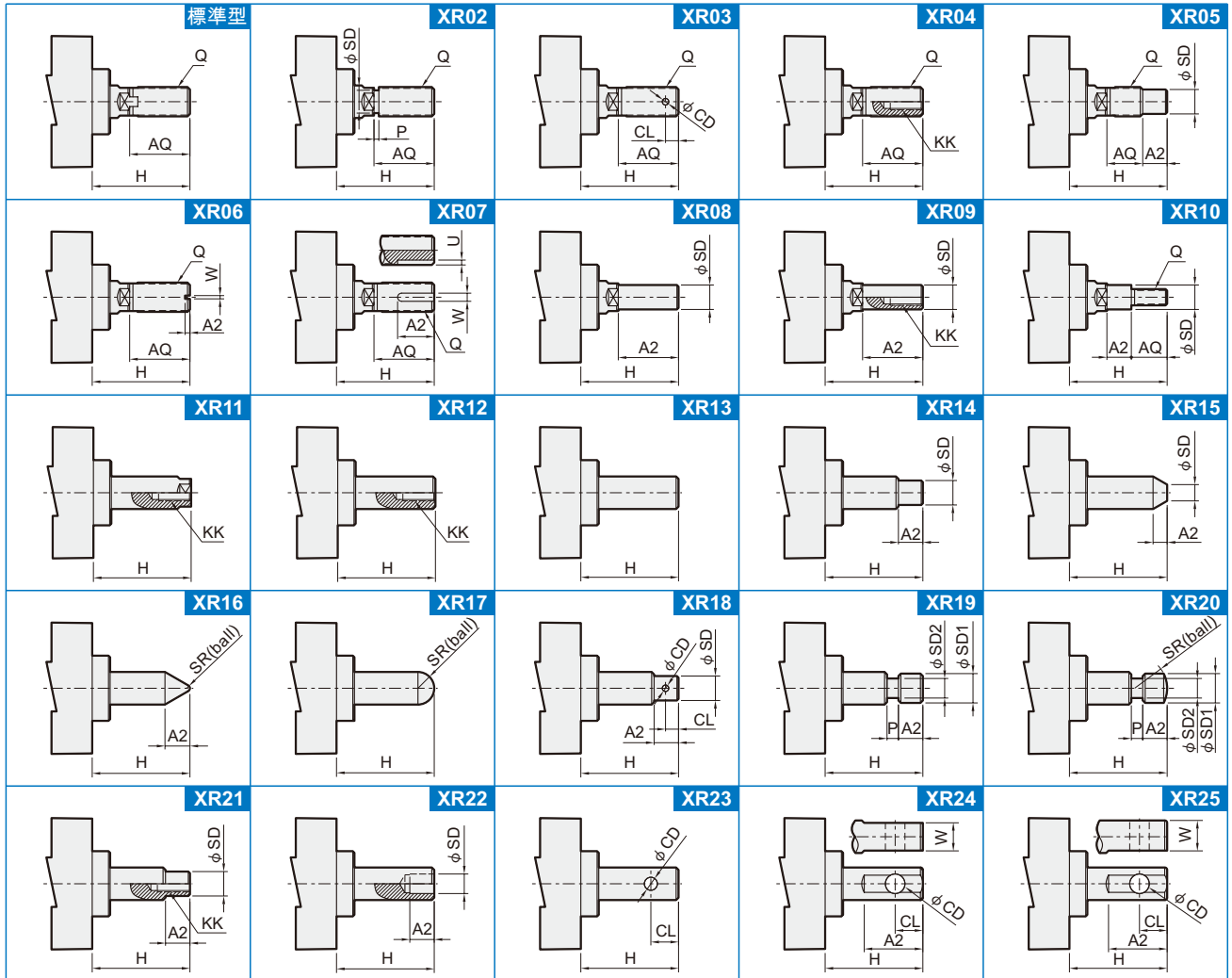

註：部份未標示尺寸，請洽業務人員。

# MCJQ / JQ2 系列

## 特殊軸端形狀



### ■ 特殊軸端形狀：



EX: MCJQ-11-40-100M-XR02 (L1=50, X=35, H1=M12×1.25)

### 11 : 外牙型

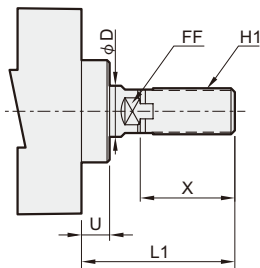

系列	內徑 (mm)	C	D	FF	H	H1	X
MCJQ	12	6	6	5	M3×0.5	M5×0.8	10.5
	16	8	8	6	M4×0.7	M6×1.0	12
	20	7	10	8	M5×0.8	M8×1.25	14
	25	12	12	10	M6×1.0	M10×1.25	17.5
	32	13	16	14	M8×1.25	M14×1.5	23.5
	40	13	16	14	M8×1.25	M14×1.5	23.5
	50	15	20	17	M10×1.5	M18×1.5	28.5
	63	15	20	17	M10×1.5	M18×1.5	28.5
	80	21	25	22	M16×2.0	M22×1.5	35.5
MCJQ2	12	6	6	5	M3×0.5	M5×0.8	10.5
	16	8	8	6	M4×0.7	M6×1.0	12
	20	10	10	8	M5×0.8	M8×1.25	14
	25	12	12	10	M6×1.0	M10×1.25	17.5

### 12 : 內牙型

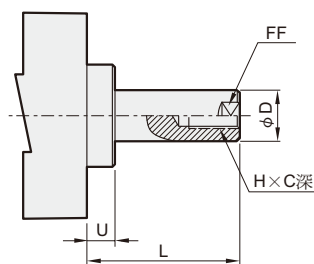

系列	內徑 (mm)	標準行程			長行程				
		行程範圍	L	L1	U	行程範圍	L	L1	U
MCJQ	12	5~30	3.5	14	—	35~100	13.5	24	—
	16	5~30	3.5	15.5	—	35~100	13.5	25.5	—
	20	5~50	4.5	18.5	—	75~200	14.5	28.5	—
	25	5~50	5	22.5	—	75~300	15	32.5	—
	32	5~100	7	28.5	—	125~300	17	38.5	5
	40	5~100	7	28.5	—	125~300	17	38.5	5
	50	5~100	8	33.5	—	125~300	18	43.5	5
	63	5~100	8	33.5	—	125~300	18	43.5	5
	80	5~100	10	43.5	—	125~300	20	53.5	5
MCJQ2	12	5~30	3.5	14	—	X	—	—	—
	16	5~30	3.5	15.5	—		—	—	—
	20	5~50	4.5	18.5	—		—	—	—
	25	5~50	5	22.5	—		—	—	—

## 特殊軸端形狀

特殊軸端形狀：

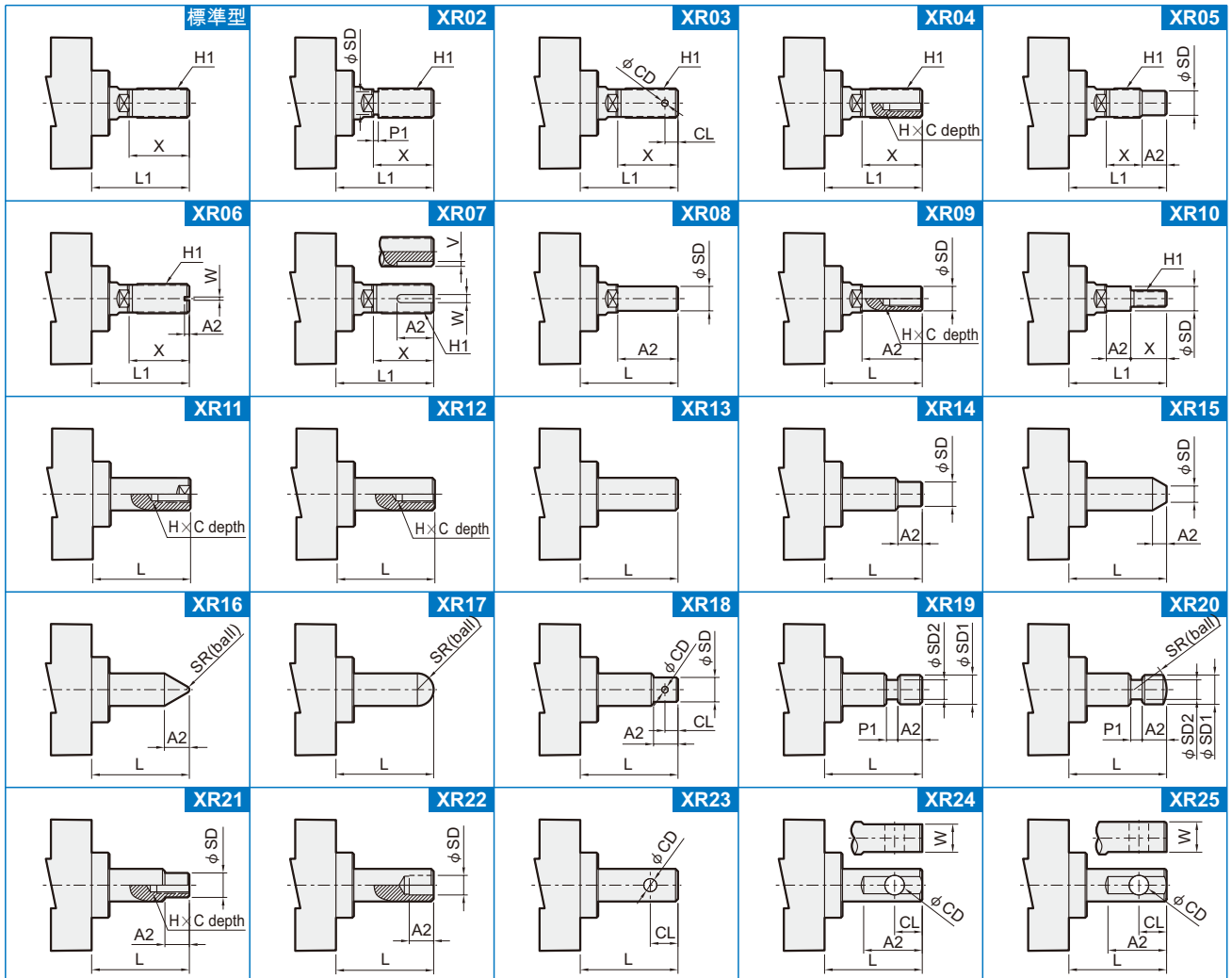

註：部份未標示尺寸，請洽業務人員。

### ■ 特殊軸端形狀：

MCMA — 標準訂購代號 — XR02

型號

MCMA  
MCMB  
MCMJ

特殊軸端形狀

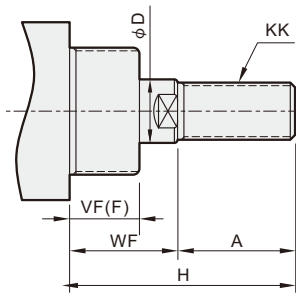

EX: MCMA-11-32-100-XR02 (A=50, WF=35, KK=M12×1.25)

系列	內徑 (mm)	A	D	WF	KK	VF(F)	H
MCMA	16	16	6	22	M6×1.0	12	—
	20	20	8	18	M8×1.25	12	—
	25	22	10	27	M10×1.25	15	—
	32	22	12	30	M10×1.25	18	—
	40	30	14	27	M12×1.25	17	—
MCMB	20	18	8	—	M8×1.25	13	41
	25	22	10	—	M10×1.25	13	45
	32	22	12	—	M10×1.25	13	45
	40	24	14	—	M14×1.5	16	50
MCMJ	8	12	4	16	M4×0.7	12	—
	10	12	4	16	M4×0.7	12	—
	12	16	6	22	M6×1.0	17	—
	16	16	6	22	M6×1.0	18	—
	20	20	8	24	M8×1.25	20	—
MCMJ	25	22	10	28	M10×1.25	22	—
	6	15	3	—	M3×0.5	8	28
	10	15	4	—	M4×0.7	8	28
16	15	5	—	M5×0.8	8	28	

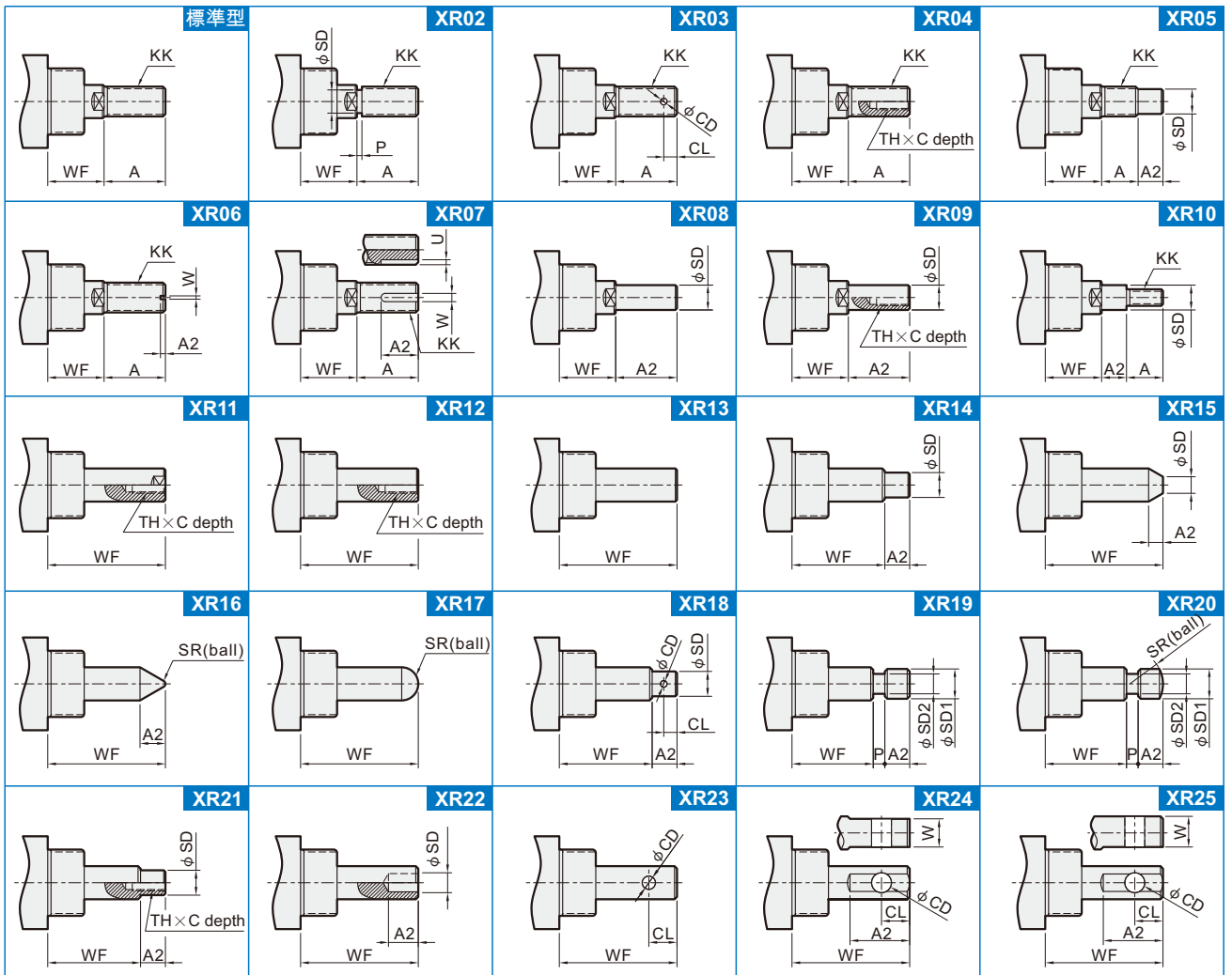

註：部份未標示尺寸，請洽業務人員。

## 特殊軸端形狀

### ■ 特殊軸端形狀：

MCCG — 標準訂購代號 — XR02

型號  
MCCG  
MCCN

特殊軸端形狀

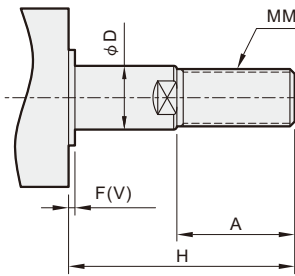

系列	內徑 (mm)	A	D	MM	F(V)	H
MCCG (mm)	20	18	8	M8×1.25	2	35
	25	22	10	M10×1.25	2	40
	32	22	12	M10×1.25	2	40
	40	30	16	M14×1.5	2	50
	50	35	20	M18×1.5	2	58
	63	35	20	M18×1.5	2	58
MCCN (inch)	20	0.50	0.315	1/4-28 UNF	0.08	—
	25	0.50	0.394	5/16-24 UNF	0.08	—
	32	0.75	0.472	7/16-20 UNF	0.08	—
	40	0.75	0.630	7/16-20 UNF	0.08	—
	50	0.88	0.787	1/2-20 UNF	0.08	—
	63	0.88	0.787	1/2-20 UNF	0.08	—

EX: MCCG-11-40-100M-XR02 (A=50, H=90, KK=M12×1.25)

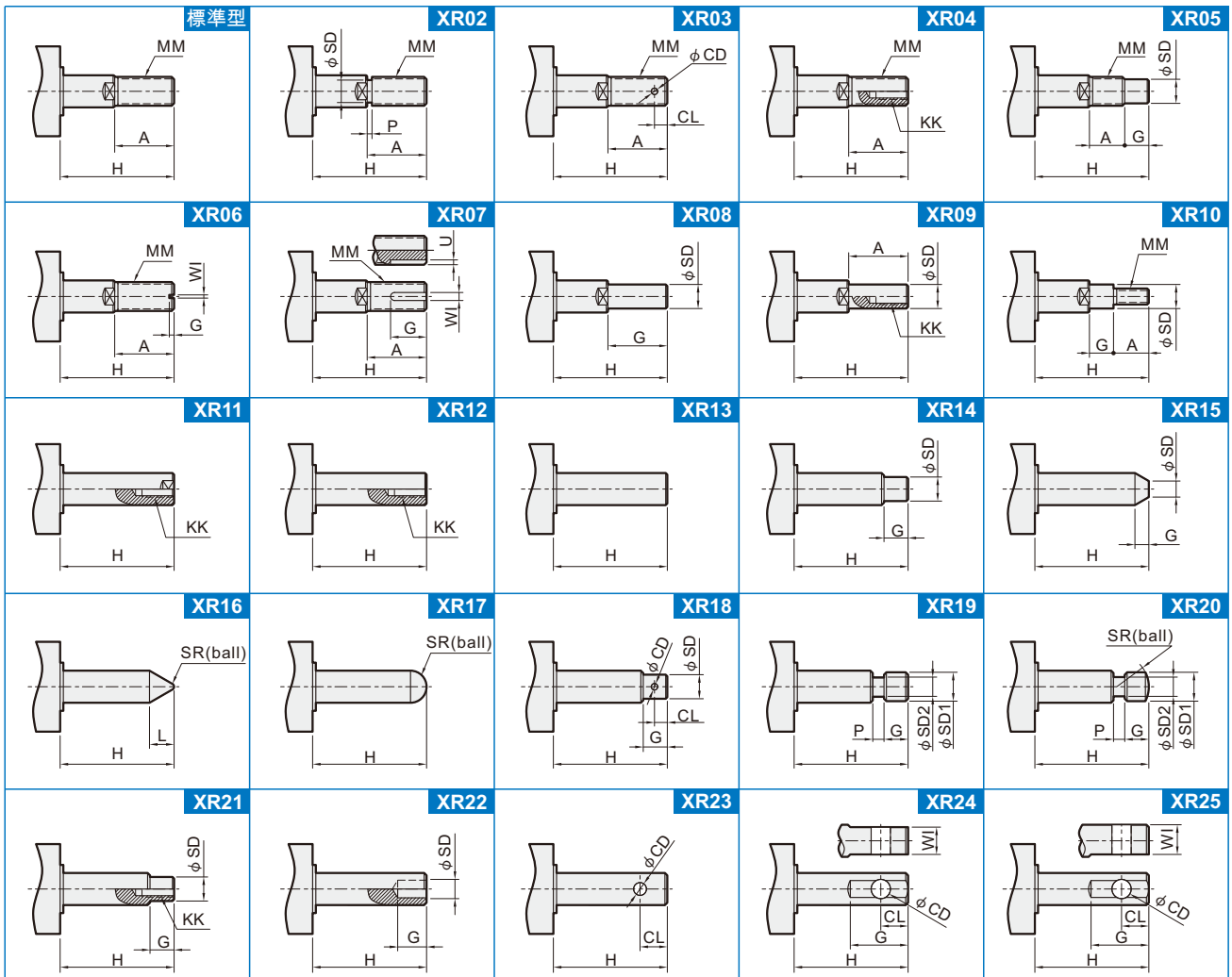

註：部份未標示尺寸，請洽業務人員。