

MHC* 系列

薄型油壓缸

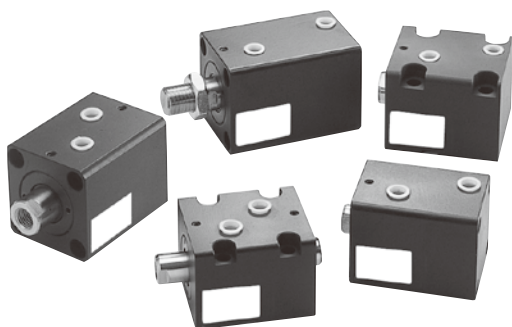

MHCB	單軸 / 軸向安裝型	
MHCQ	單軸 / 側向安裝型	
MHCB-D	雙軸 / 軸向安裝型	
MHCQ-D	雙軸 / 側向安裝型	
MHC*-DA	雙軸 / 可調行程 25 mm	
MHC*-DB	雙軸 / 可調行程 50 mm	

特點

- 薄型油壓缸比一般油壓缸較節省空間，相當適用於小型機械或空間受到限制的場合。
- 本系列油壓缸內壁經特殊加工處理，較表面光滑，增長使用壽命。
- 外型設計輕巧、美觀堅固。

規格

型號	MHC*						
油缸內徑 (mm)	20	25	32	40	50	63	80
行程範圍 (mm)	30	30	60	80	90	100	
使用流體	已濾清之標準液壓油						
缸體材質	碳鋼						
最大使用壓力	14 MPa						
使用溫度範圍	-10~+60°C (不凍結)						

訂購代號

MHCB — 50 — 30 — ZDA

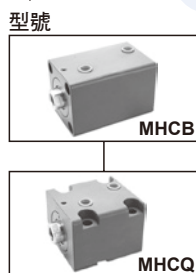
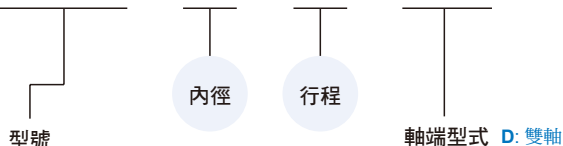

軸端型式 D: 雙軸			
無		單軸 / 內牙	ZD
Z		單軸 / 外牙	ZDA
D		雙軸 / 兩端內牙	ZDB
DA		雙軸 / 內牙 / 可調行程 25mm	LD
DB		雙軸 / 內牙 / 可調行程 50mm	RD

標準行程表

●標準品 ○訂製品

型號	行程 內徑	5	10	15	20	25	30	35	40	45	50	60	70	80	90	100	
MHCB MHCB-Z	ø20	○	●	○	●	○	●	○	●	—	—	—	—	—	—	—	
	ø25	○	●	○	●	○	●	○	●	○	●	—	—	—	—	—	
	ø32	●	●	●	●	●	●	○	●	○	●	●	—	—	—	—	
	ø40	●	●	●	●	●	●	○	●	○	●	●	●	●	—	—	
	ø50	●	●	●	●	●	●	○	●	○	●	●	●	●	●	—	
	ø63	●	●	●	●	●	●	○	●	○	●	●	●	●	●	●	●
	ø80	●	●	●	●	●	●	○	●	○	●	●	●	●	●	●	●
MHCB-D MHCB-ZD MHCB-LD	ø32	○	●	○	●	○	●	○	●	○	●	—	—	—	—	—	
	ø40	○	●	○	●	○	●	○	●	○	●	—	—	—	—	—	
	ø50	○	●	○	●	○	●	○	●	○	●	—	—	—	—	—	
	ø63	○	●	○	●	○	●	○	●	○	●	—	—	—	—	—	
	ø80	○	●	○	●	○	●	○	●	○	●	—	—	—	—	—	
MHCB-DA MHCB-ZDA MHCB-DB MHCB-ZDB	ø32	○	●	○	●	○	●	○	●	○	●	—	—	—	—	—	
	ø40	○	●	○	●	○	●	○	●	○	●	—	—	—	—	—	
	ø50	○	●	○	●	○	●	○	●	○	●	—	—	—	—	—	
	ø63	○	●	○	●	○	●	○	●	○	●	—	—	—	—	—	
	ø80	○	●	○	●	○	●	○	●	○	●	—	—	—	—	—	
MHCQ MHCQ-Z	ø32	○	●	○	●	○	●	○	●	○	●	—	—	—	—	—	
	ø40	○	●	○	●	○	●	○	●	○	●	—	—	—	—	—	
	ø50	○	●	○	●	○	●	○	●	○	●	—	—	—	—	—	
	ø63	○	●	○	●	○	●	○	●	○	●	—	—	—	—	—	
MHCQ-D MHCQ-ZD MHCQ-RD MHCQ-LD	ø32	○	●	○	●	○	●	○	●	○	●	—	—	—	—	—	
	ø40	○	●	○	●	○	●	○	●	○	●	—	—	—	—	—	
	ø50	○	●	○	●	○	●	○	●	○	●	—	—	—	—	—	
	ø63	○	●	○	●	○	●	○	●	○	●	—	—	—	—	—	
MHCQ-DA MHCQ-ZDA MHCQ-DB MHCQ-ZDB	ø32	○	●	○	●	○	●	○	●	○	●	—	—	—	—	—	
	ø40	○	●	○	●	○	●	○	●	○	●	—	—	—	—	—	
	ø50	○	●	○	●	○	●	○	●	○	●	—	—	—	—	—	
	ø63	○	●	○	●	○	●	○	●	○	●	—	—	—	—	—	

理論出力表

單位: KN

缸徑 (mm)	軸徑 (mm)	受壓面積 (mm ²)	操作壓力 (MPa)									
			6	7	8	9	10	11	12	13	14	
ø20	ø12	A	314	1.88	2.20	2.51	2.83	3.14	3.46	3.77	4.08	4.40
		B	201	1.21	1.41	1.61	1.81	2.01	2.21	2.41	2.61	2.81
ø25	ø14	A	491	2.95	3.44	3.93	4.42	4.91	5.40	5.89	6.38	6.87
		B	337	2.02	2.36	2.70	3.03	3.37	3.71	4.04	4.38	4.72
ø32	ø20	A	804	4.83	5.63	6.43	7.24	8.04	8.85	9.65	10.46	11.26
		B	490	2.94	3.43	3.92	4.41	4.90	5.39	5.88	6.37	6.86
ø40	ø25	A	1257	7.54	8.80	10.05	11.31	12.57	13.82	15.08	16.34	17.59
		B	766	4.59	5.36	6.13	6.89	7.66	8.42	9.19	9.95	10.72
ø50	ø30	A	1963	11.78	13.74	15.71	17.67	19.63	21.60	23.56	25.53	27.49
		B	1257	7.54	8.80	10.05	11.31	12.57	13.82	15.08	16.34	17.59
ø63	ø35	A	3117	18.70	21.82	24.94	28.06	31.17	34.29	37.41	40.52	43.64
		B	2155	12.93	15.09	17.24	19.40	21.55	23.71	25.86	28.02	30.17
ø80	ø45	A	5027	30.16	35.19	40.21	45.24	50.27	55.29	60.32	65.35	70.37
		B	3436	20.62	24.05	27.49	30.93	34.36	37.80	41.23	44.67	48.11

油壓缸出力計算方式

$$F = P \times A - f$$

F:	油缸出力	(N)
P:	使用壓力	(MPa)
A:	截面積	(mm ²)
f:	摩擦阻力	(N)

修理包 / 訂購代號

MHC□SK □

B
Q

內徑	修理包	
20	MHCB20	- 包括 No.6,7,8,9,10
25	MHCB25	- 包括 No.6,7,8,9,10
32	MHCB32,MHCQ32	- 包括 No.6,7,8,9,10
40	MHCB40,MHCQ40	- 包括 No.6,7,8,9,10
50	MHCB50,MHCQ50	- 包括 No.6,7,8,9,10
63	MHCB63,MHCQ63	- 包括 No.6,7,8,9,10
80	MHCB80	- 包括 No.6,7,8,9,10

MHC□SK □ D

B
Q

內徑	修理包	
32	MHCB32D,MHCQ32D	- 包括 No.6,7,8,9,10
40	MHCB40D,MHCQ40D	- 包括 No.6,7,8,9,10
50	MHCB50D,MHCQ50D	- 包括 No.6,7,8,9,10
63	MHCB63D,MHCQ63D	- 包括 No.6,7,8,9,10
80	MHCB80D	- 包括 No.6,7,8,9,10

MHCB

MHCQ

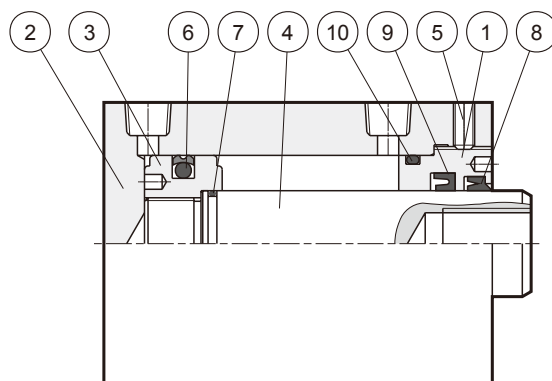

零件表

No.	名稱	數量	No.	名稱	數量	No.	名稱	數量
1	前蓋	1	5	止付螺絲	1	9	軸封	1
2	油缸本體	1	6	活塞迫緊	1	10	前蓋 O 型環	1
3	活塞本體	1	7	活塞 O 型環	1	11		
4	活塞桿	1	8	灰塵刮刷環	1	12		

MHCB-D

MHCQ-D

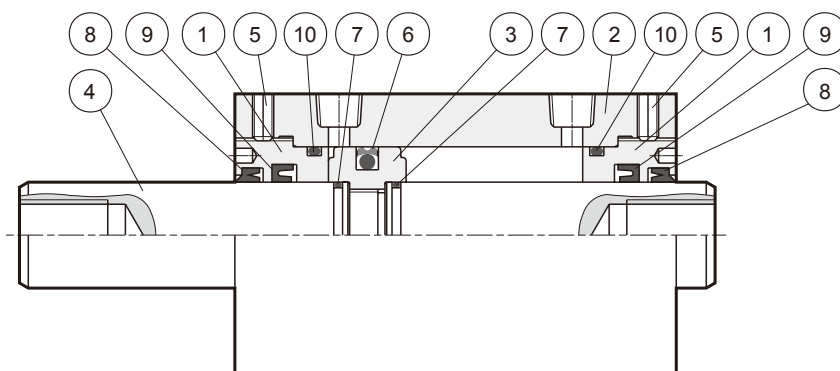

零件表

No.	名稱	數量	No.	名稱	數量	No.	名稱	數量
1	前蓋	1	5	止付螺絲	1	9	軸封	2
2	油缸本體	1	6	活塞迫緊	1	10	前蓋 O 型環	2
3	活塞本體	1	7	活塞 O 型環	1	11		
4	活塞桿	1	8	灰塵刮刷環	1	12		

修理包 / 訂購代號

MHC□SK □ D

B
Q

內徑	修理包
32	MHCBSK32D, MHCQSK32D - 包括 No.6,7,8,9,10
40	MHCBSK40D, MHCQSK40D - 包括 No.6,7,8,9,10
50	MHCBSK50D, MHCQSK50D - 包括 No.6,7,8,9,10
63	MHCBSK63D, MHCQSK63D - 包括 No.6,7,8,9,10
80	MHCBSK80D - 包括 No.6,7,8,9,10

MHCB-DA

MHCB-DB

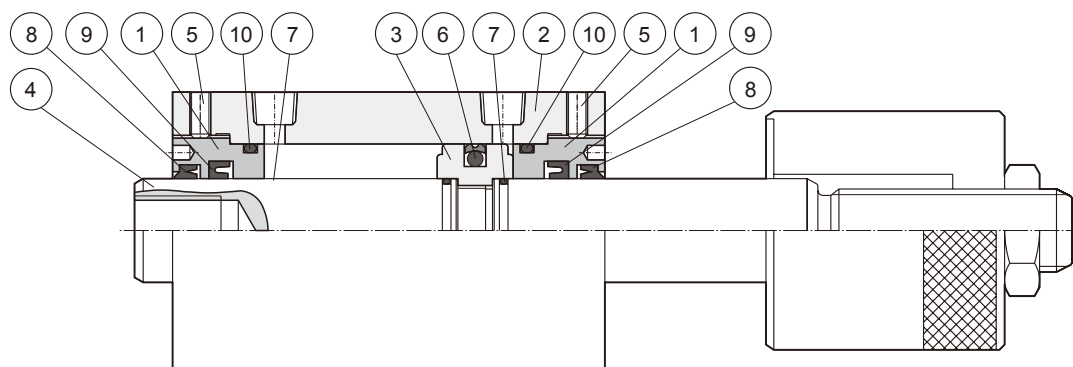

零件表

No.	名稱	數量	No.	名稱	數量	No.	名稱	數量
1	前蓋	2	5	止付螺絲	2	9	軸封	2
2	油缸本體	1	6	活塞迫緊	1	10	前蓋 O 型環	2
3	活塞本體	1	7	活塞 O 型環	2	11		
4	活塞桿	1	8	灰塵刮刷環	2	12		

MHCQ-DA

MHCQ-DB

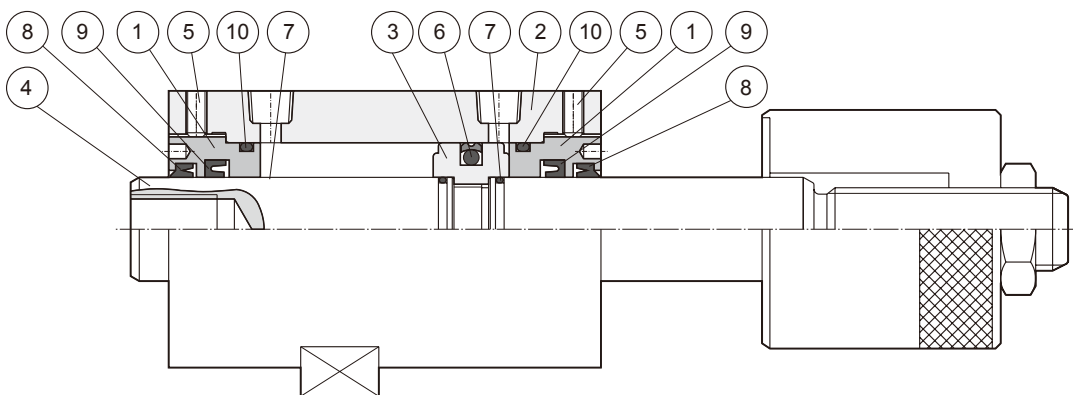

零件表

No.	名稱	數量	No.	名稱	數量	No.	名稱	數量
1	前蓋	2	5	止付螺絲	2	9	軸封	2
2	油缸本體	1	6	活塞迫緊	1	10	前蓋 O 型環	2
3	活塞本體	1	7	活塞 O 型環	2	11		
4	活塞桿	1	8	灰塵刮刷環	2	12		

重量表

內徑 型號	$\phi 20$		$\phi 25$		$\phi 32$				$\phi 40$				$\phi 50$				$\phi 63$				$\phi 80$	
	MHCB	MHCB	MHCB	MHCB	MHCB	MHCQ	MHCB	MHCQ	MHCB	MHCQ	MHCB	MHCQ	MHCB	MHCQ	MHCB	MHCQ	MHCB	MHCQ	MHCB	MHCQ	MHCB	MHCQ
行程	N	Z	N	Z	N	Z	N	Z	N	Z	N	Z	N	Z	N	Z	N	Z	N	Z	N	Z
5	0.64	0.69	0.88	0.93	1.61	1.71	1.72	1.82	2.00	2.20	2.21	2.41	2.78	3.03	3.27	3.52	4.24	4.69	5.28	5.73	7.46	8.31
10	0.63	0.68	0.87	0.92	1.73	1.83	1.71	1.81	2.15	2.35	2.19	2.39	2.96	3.21	3.24	3.49	4.48	4.93	5.22	5.67	7.80	8.65
15	0.75	0.80	1.02	1.07	1.85	1.95	1.98	2.08	2.30	2.50	2.55	2.75	3.14	3.39	3.71	3.96	4.72	5.17	5.90	6.35	8.14	8.99
20	0.74	0.79	1.01	1.06	1.97	2.07	1.97	2.07	2.45	2.65	2.53	2.73	3.32	3.57	3.68	3.93	4.96	5.41	5.84	6.29	8.48	9.33
25	0.86	0.91	1.16	1.21	2.09	2.19	2.24	2.34	2.60	2.80	2.89	3.09	3.50	3.75	4.15	4.40	5.20	5.65	6.52	6.97	8.82	9.67
30	0.85	0.90	1.15	1.20	2.21	2.31	2.23	2.33	2.75	2.95	2.87	3.07	3.68	3.93	4.12	4.37	5.44	5.89	6.46	6.91	9.16	10.01
35	0.97	1.02	1.30	1.35	2.46	2.56	2.50	2.60	3.07	3.27	3.23	3.43	4.07	4.32	4.59	4.84	5.98	6.43	7.14	7.59	9.93	10.78
40	0.96	1.01	1.29	1.34	2.45	2.55	2.49	2.59	3.05	3.25	3.21	3.41	4.04	4.29	4.56	4.81	5.92	6.37	7.08	7.53	9.84	10.69
45	—	—	1.44	1.49	2.70	2.80	2.76	2.86	3.37	3.57	3.57	3.77	4.43	4.68	5.03	5.28	6.46	6.91	7.76	8.21	10.61	11.46
50	—	—	1.43	1.48	2.69	2.79	2.75	2.85	3.35	3.55	3.55	3.75	4.40	4.65	5.00	5.25	6.40	6.85	7.70	8.15	10.52	11.37
60	—	—	—	—	2.93	3.03	3.01	3.11	3.65	3.85	3.89	4.09	4.76	5.01	5.44	5.69	6.88	7.33	8.32	8.77	11.20	12.05
70	—	—	—	—	3.17	3.27	3.27	3.37	3.95	4.15	4.23	4.43	5.12	5.37	5.88	6.13	7.36	7.81	8.94	9.39	11.88	12.73
80	—	—	—	—	3.41	3.51	3.53	3.63	4.25	4.45	4.57	4.77	5.48	5.73	6.32	6.57	7.84	8.29	9.56	10.01	12.56	13.41
90	—	—	—	—	3.65	3.75	3.79	3.89	4.55	4.75	4.91	5.11	5.84	6.09	6.76	7.01	8.32	8.77	10.18	10.63	13.24	14.09
100	—	—	—	—	3.89	3.99	4.05	4.15	4.85	5.05	5.25	5.45	6.20	6.45	7.20	7.45	8.80	9.25	10.80	11.25	13.92	14.77

* N: 內牙; Z: 外牙

內徑 型號	$\phi 32$						$\phi 40$						$\phi 50$						$\phi 63$						$\phi 80$		
	MHCB_D			MHCQ_D			MHCB_D			MHCQ_D			MHCB_D			MHCQ_D			MHCB_D			MHCQ_D			MHCB_D		
行程	N	Z	L	N	Z	L,R	N	Z	L	N	Z	L,R	N	Z	L	N	Z	L,R	N	Z	L	N	Z	L,R	N	Z	L
5	1.89	2.06	1.97	1.90	2.07	1.99	2.37	2.71	2.54	2.45	2.79	2.62	3.22	3.65	3.44	3.63	4.05	3.84	4.85	5.61	5.23	5.59	6.35	5.98	10.18	11.63	10.90
10	1.89	2.06	1.97	1.90	2.07	1.99	2.37	2.71	2.54	2.45	2.79	2.62	3.22	3.65	3.43	3.62	4.05	3.84	4.83	5.59	5.21	5.58	6.34	5.96	10.15	11.60	10.88
15	2.11	2.28	2.20	2.14	2.31	2.23	2.66	3.00	2.83	2.77	3.11	2.94	3.58	4.00	3.79	4.05	4.47	4.26	5.32	6.08	5.70	6.18	6.95	6.57	10.87	12.31	11.59
20	2.11	2.28	2.20	2.14	2.31	2.23	2.66	3.00	2.83	2.77	3.11	2.94	3.57	4.00	3.79	4.04	4.47	4.26	5.30	6.07	5.68	6.17	6.93	6.55	10.84	12.28	11.58
25	2.34	2.51	2.42	2.38	2.55	2.47	2.94	3.28	3.11	3.09	3.43	3.26	3.93	4.36	4.14	4.47	4.90	4.68	5.79	6.56	6.17	6.78	7.54	7.16	11.55	12.99	12.27
30	2.34	2.51	2.42	2.39	2.56	2.47	2.95	3.29	3.12	3.10	3.44	3.27	3.93	4.35	4.14	4.47	4.89	4.68	5.77	6.54	6.15	6.76	7.52	7.14	11.52	12.97	12.25
35	2.56	2.73	2.65	2.63	2.80	2.71	3.23	3.57	3.40	3.42	3.76	3.59	4.28	4.71	4.50	4.89	5.32	5.10	6.26	7.03	6.64	7.37	8.13	7.75	12.23	13.68	12.96
40	2.56	2.73	2.65	2.63	2.80	2.71	3.23	3.57	3.40	3.42	3.76	3.59	4.28	4.71	4.49	4.89	5.31	5.10	6.24	7.01	6.63	7.35	8.11	7.73	12.21	13.65	12.93
45	2.79	2.96	2.87	2.87	3.04	2.95	3.52	3.86	3.69	3.74	4.08	3.91	4.64	5.06	4.85	5.31	5.74	5.52	6.73	7.50	7.12	7.96	8.72	8.34	12.92	14.35	13.64
50	2.79	2.96	2.87	2.87	3.04	2.96	3.52	3.86	3.69	3.74	4.08	3.91	4.63	5.06	4.85	5.31	5.73	5.52	6.72	7.48	7.10	7.94	8.71	8.32	12.89	14.34	13.61

* N: 雙內牙; Z: 雙外牙; L, R: 單邊外牙, 另一邊內牙。

配件 / 重量表

單位: kg

內徑 (mm)	可調螺帽		軸心螺帽
	A 可調行程 25mm	B 可調行程 50mm	
$\phi 32$	0.6	0.9	0.02
$\phi 40$	1.0	1.45	0.04
$\phi 50$	1.15	1.7	0.08
$\phi 63$	2.15	3	0.08
$\phi 80$	3.4	4.2	0.18

MHCB 外觀尺寸 $\phi 20 \sim \phi 80$

薄型油壓缸



MHCB

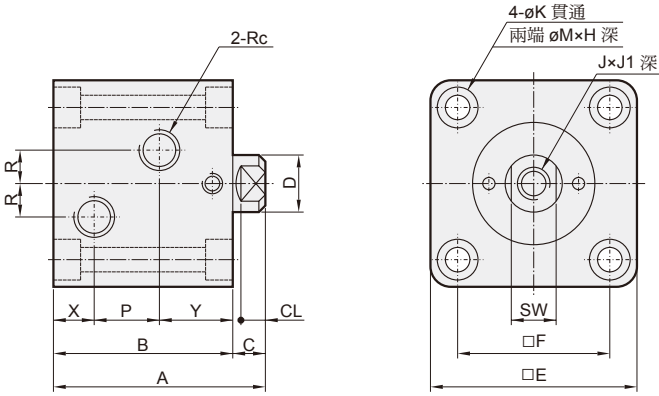

MHCB-D

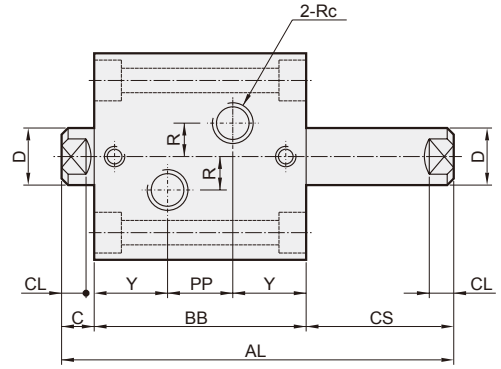

CS=C+行程

MHCB-Z

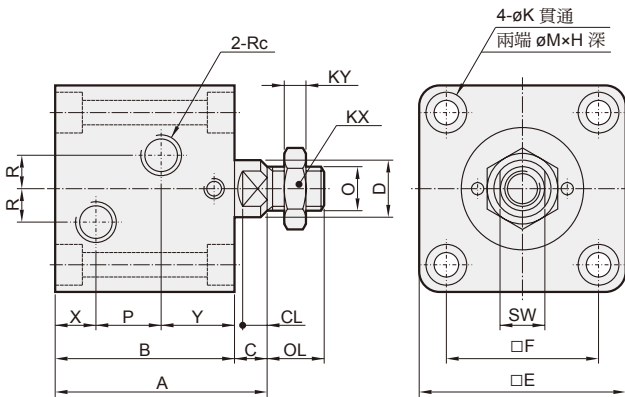

MHCB-ZD

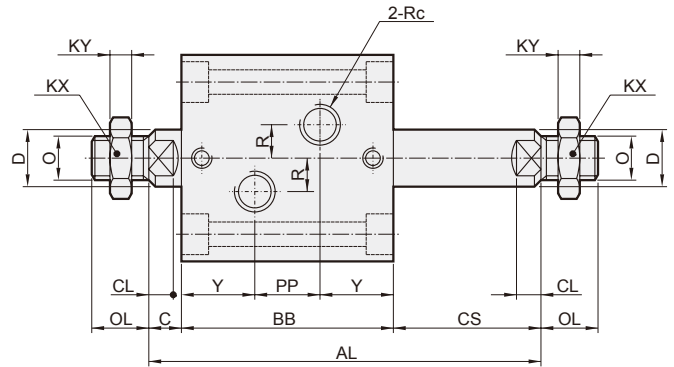

CS=C+行程

MHCB-LD

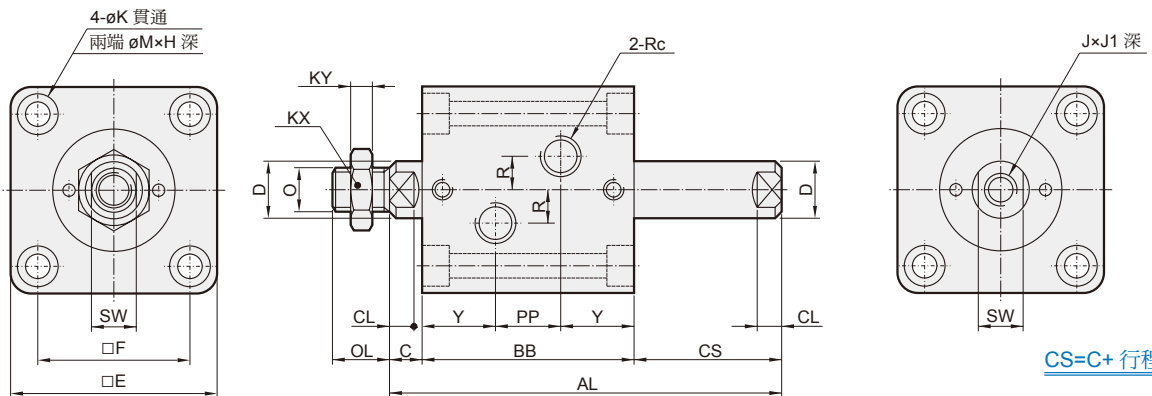

CS=C+行程

MHCB 外觀尺寸 $\phi 20 \sim \phi 80$



薄型油壓缸

Mindman

內徑	型式	MHCB / MHCB-Z														
	代號 / 行程	5	10	15	20	25	30	35	40	45	50	60	70	80	90	100
$\phi 20$	A	61	61	71	71	81	81	91	91	-	-	-	-	-	-	-
	B	53	53	63	63	73	73	83	83	-	-	-	-	-	-	-
	P	20	20	30	30	40	40	50	50	-	-	-	-	-	-	-
$\phi 25$	A	63	63	73	73	83	83	93	93	103	103	-	-	-	-	-
	B	55	55	65	65	75	75	85	85	95	95	-	-	-	-	-
	P	22	22	32	32	42	42	52	52	62	62	-	-	-	-	-
$\phi 32$	A	69	74	79	84	89	94	104	104	114	114	124	-	-	-	-
	B	59	64	69	74	79	84	94	94	104	104	114	-	-	-	-
	P	19	24	29	34	39	44	54	54	64	64	74	-	-	-	-
$\phi 40$	A	70	75	80	85	90	95	105	105	115	115	125	135	145	-	-
	B	60	65	70	75	80	85	95	95	105	105	115	125	135	-	-
	P	20	25	30	35	40	45	55	55	65	65	75	85	95	-	-
$\phi 50$	A	76	81	86	91	96	101	111	111	121	121	131	141	151	161	-
	B	65	70	75	80	85	90	100	100	110	110	120	130	140	150	-
	P	23	28	33	38	43	48	58	58	68	68	78	88	98	108	-
$\phi 63$	A	85	90	95	100	105	110	120	120	130	130	140	150	160	170	180
	B	72	77	82	87	92	97	107	107	117	117	127	137	147	157	167
	P	25	30	35	40	45	50	60	60	70	70	80	90	100	110	120
$\phi 80$	A	100	105	110	115	120	125	135	135	145	145	155	165	175	185	195
	B	83	88	93	98	103	108	118	118	128	128	138	148	158	168	178
	P	32	37	42	47	52	57	67	67	77	77	87	97	107	117	127

內徑	型式	MHCB-D / MHCB-ZD / MHCB-LD														
	代號 / 行程	5	10	15	20	25	30	35	40	45	50	60	70	80	90	100
$\phi 32$	AL	104	109	124	129	144	149	164	169	184	189	-	-	-	-	-
	BB	79	79	89	89	99	99	109	109	119	119	-	-	-	-	-
	CS	15	20	25	30	35	40	45	50	55	60	-	-	-	-	-
	PP	23	23	33	33	43	43	53	53	63	63	-	-	-	-	-
$\phi 40$	AL	105	110	125	130	145	150	165	170	185	190	-	-	-	-	-
	BB	80	80	90	90	100	100	110	110	120	120	-	-	-	-	-
	CS	15	20	25	30	35	40	45	50	55	60	-	-	-	-	-
	PP	24	24	34	34	44	44	54	54	64	64	-	-	-	-	-
$\phi 50$	AL	112	117	132	137	152	157	172	177	192	197	-	-	-	-	-
	BB	85	85	95	95	105	105	115	115	125	125	-	-	-	-	-
	CS	16	21	26	31	36	41	46	51	56	61	-	-	-	-	-
	PP	26	26	36	36	46	46	56	56	66	66	-	-	-	-	-
$\phi 63$	AL	123	128	143	148	163	168	183	188	203	208	-	-	-	-	-
	BB	92	92	102	102	112	112	122	122	132	132	-	-	-	-	-
	CS	18	23	28	33	38	43	48	53	58	63	-	-	-	-	-
	PP	30	30	40	40	50	50	60	60	70	70	-	-	-	-	-
$\phi 80$	AL	142	147	162	167	182	187	202	207	222	227	-	-	-	-	-
	BB	103	103	113	113	123	123	133	133	143	143	-	-	-	-	-
	CS	22	27	32	37	42	47	52	57	62	67	-	-	-	-	-
	PP	37	37	47	47	57	57	67	67	77	77	-	-	-	-	-

代號 / 內徑	C	CL	D	E	F	H	J	J1	K	KX	KY	M	O	OL	PT	R	SW	X	Y
$\phi 20$	8	6	12	42	30	5.5	M8×1.25	12	5.6	17	6	9	M10×1.25	20	Rc1/8	5	10	10	23
$\phi 25$	8	6	14	48	36	5.5	M10×1.5	15	5.6	19	7	9	M12×1.25	22	Rc1/8	5	12	10	23
$\phi 32$	10	7	20	62	47	6.5	M12×1.75	15	6.6	24	8	11	M16×1.5	25	Rc1/4	10	17	12	28
$\phi 40$	10	7	25	70	52	9	M16×2.0	20	9	32	11	14	M22×1.5	30	Rc1/4	10	22	12	28
$\phi 50$	11	8	30	80	58	11	M20×2.5	25	11	35	14	18	M26×1.5	35	Rc1/4	10	27	12.5	29.5
$\phi 63$	13	10	35	94	69	13	M27×3.0	35	13	41	13	20	M30×1.5	40	Rc3/8	10	32	16	31
$\phi 80$	17	14	45	114	86	15	M30×3.5	35	15	50	10	22	M39×1.5	45	Rc3/8	15	41	18	33

MHCQ

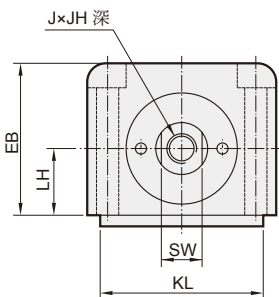
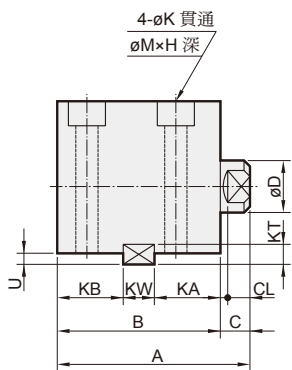
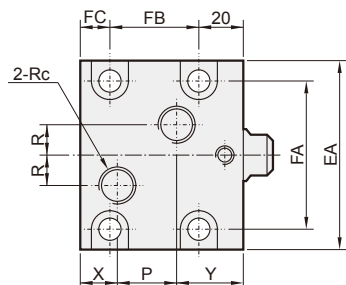

MHCQ-D

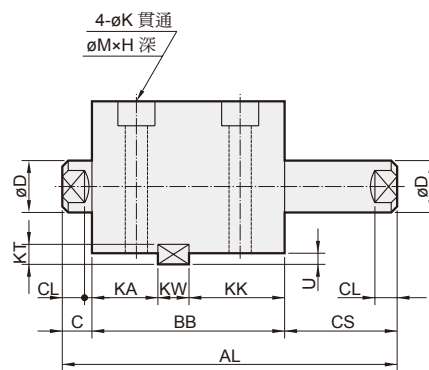
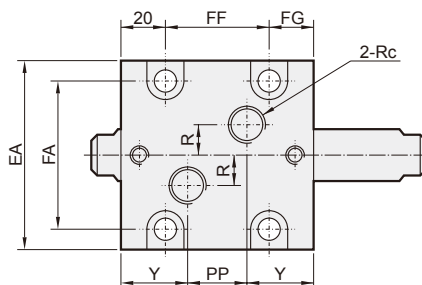

CS=C+行程

MHCQ-Z

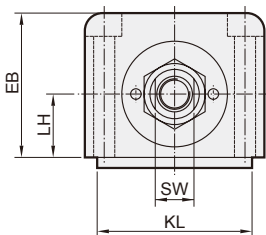
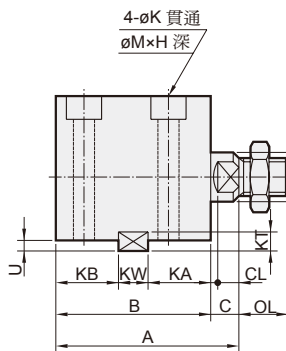
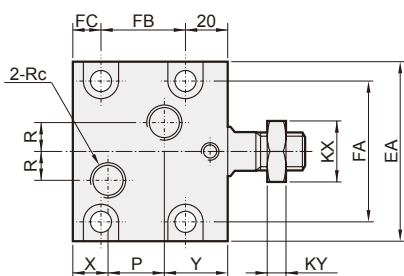

MHCQ-ZD

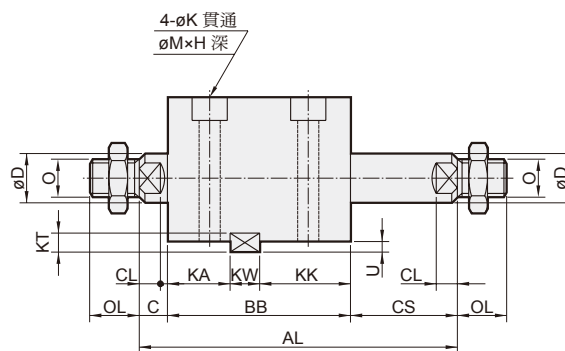
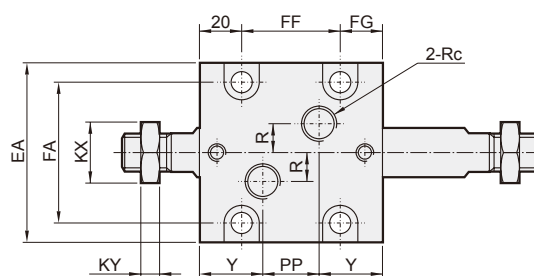

CS=C+行程

內徑	型式	MHCQ / MHCQ-Z									
	代號 / 行程	5	10	15	20	25	30	35	40	45	50
$\phi 32$	A	74	74	84	84	94	94	104	104	114	114
	B	64	64	74	74	84	84	94	94	104	104
	FB	34	34	44	44	54	54	64	64	74	74
	KB	24	24	34	34	44	44	54	54	64	64
	P	24	24	34	34	44	44	54	54	64	64
$\phi 40$	A	75	75	85	85	95	95	105	105	115	115
	B	65	65	75	75	85	85	95	95	105	105
	FB	33	33	43	43	53	53	63	63	73	73
	KB	25	25	35	35	45	45	55	55	65	65
	P	25	25	35	35	45	45	55	55	65	65
$\phi 50$	A	81	81	91	91	101	101	111	111	121	121
	B	70	70	80	80	90	90	100	100	110	110
	FB	37	37	47	47	57	57	67	67	77	77
	KB	27	27	37	37	47	47	57	57	67	67
	P	28	28	38	38	48	48	58	58	68	68
$\phi 63$	A	90	90	100	100	110	110	120	120	130	130
	B	77	77	87	87	97	97	107	107	117	117
	FB	42	42	52	52	62	62	72	72	82	82
	KB	30	30	40	40	50	50	60	60	70	70
	P	30	30	40	40	50	50	60	60	70	70

內徑	型式	MHCQ-D / MHCQ-ZD									
	代號 / 行程	5	10	15	20	25	30	35	40	45	50
$\phi 32$	AA	104	109	124	129	144	149	164	169	184	189
	BB	79	79	89	89	99	99	109	109	119	119
	CS	15	20	25	30	35	40	45	50	55	60
	FF	42	42	52	52	62	62	72	72	82	82
	KK	39	39	49	49	59	59	69	69	79	79
	PP	23	23	33	33	43	43	53	53	63	63
$\phi 40$	AA	105	110	125	130	145	150	165	170	185	190
	BB	80	80	90	90	100	100	110	110	120	120
	CS	15	20	25	30	35	40	45	50	55	60
	FF	42	42	52	52	62	62	72	72	82	82
	KK	40	40	50	50	60	60	70	70	80	80
	PP	24	24	34	34	44	44	54	54	64	64
$\phi 50$	AA	112	117	132	137	152	157	172	177	192	197
	BB	85	85	95	95	105	105	115	115	125	125
	CS	16	21	26	31	36	41	46	51	56	61
	FF	45	45	55	55	65	65	75	75	85	85
	KK	42	42	52	52	62	62	72	72	82	82
	PP	26	26	36	36	46	46	56	56	66	66
$\phi 63$	AA	123	128	143	148	163	168	183	188	203	208
	BB	92	92	102	102	112	112	122	122	132	132
	CS	18	23	28	33	38	43	48	53	58	63
	FF	52	52	62	62	72	72	82	82	92	92
	KK	45	45	55	55	65	65	75	75	85	85
	PP	30	30	40	40	50	50	60	60	70	70

代號 內徑	C	CL	D	EA	EB	FA	FC	FG	H	J	JH	K	KA	KL
$\phi 32$	10	7	20	70	56	56	10	17	9	M12×1.75	15	9	28	63
$\phi 40$	10	7	25	80	64	62	12	18	11	M16×2.0	20	11	28	70
$\phi 50$	11	8	30	94	74	74	13	20	13	M20×2.5	25	13	29	80
$\phi 63$	13	10	35	114	89	90	15	20	15	M27×3.0	35	15	31	100

代號 內徑	KT	KW	KX	KY	LH	M	O	OL	PT	R	SW	U	X	Y
$\phi 32$	8	12	24	8	25	14	M16×1.5	25	Rc1/4	10	17	4.5	12	28
$\phi 40$	8	12	32	11	29	18	M22×1.5	30	Rc1/4	10	22	4.5	12	28
$\phi 50$	9	14	35	14	34	20	M26×1.5	35	Rc1/4	10	27	5	12.5	29.5
$\phi 63$	10	16	41	13	42	22	M30×1.5	40	Rc3/8	10	32	5.5	16	31

MHCQ-*D 外觀尺寸 - 雙軸型 $\phi 32 \sim \phi 63$

薄型油壓缸



MHCQ-RD

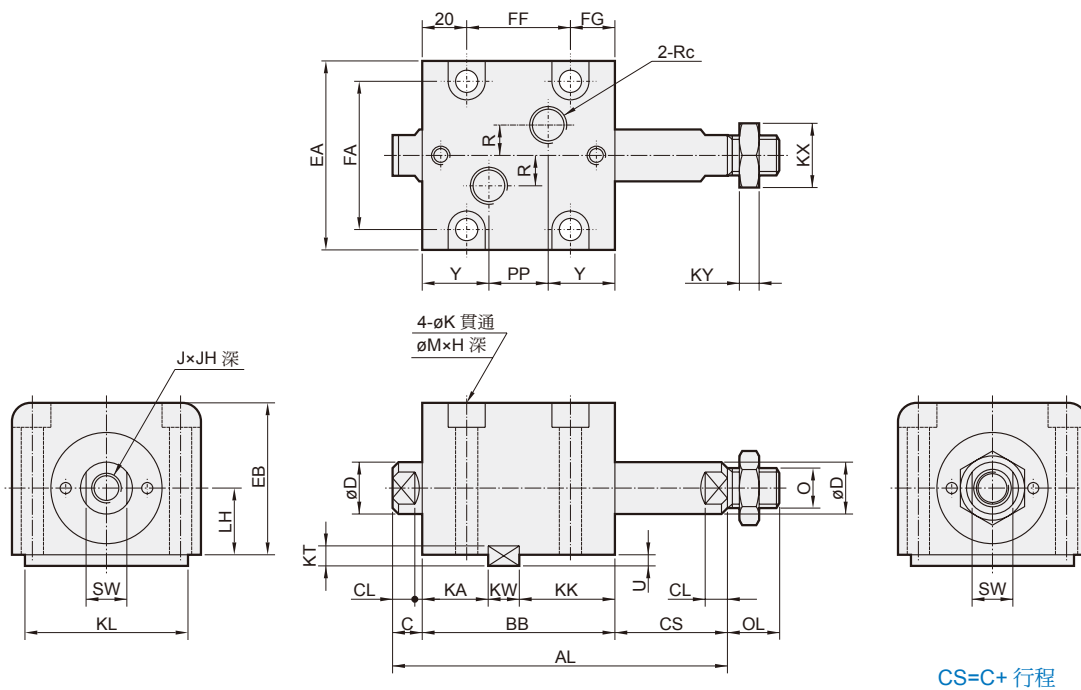

MHCQ-LD

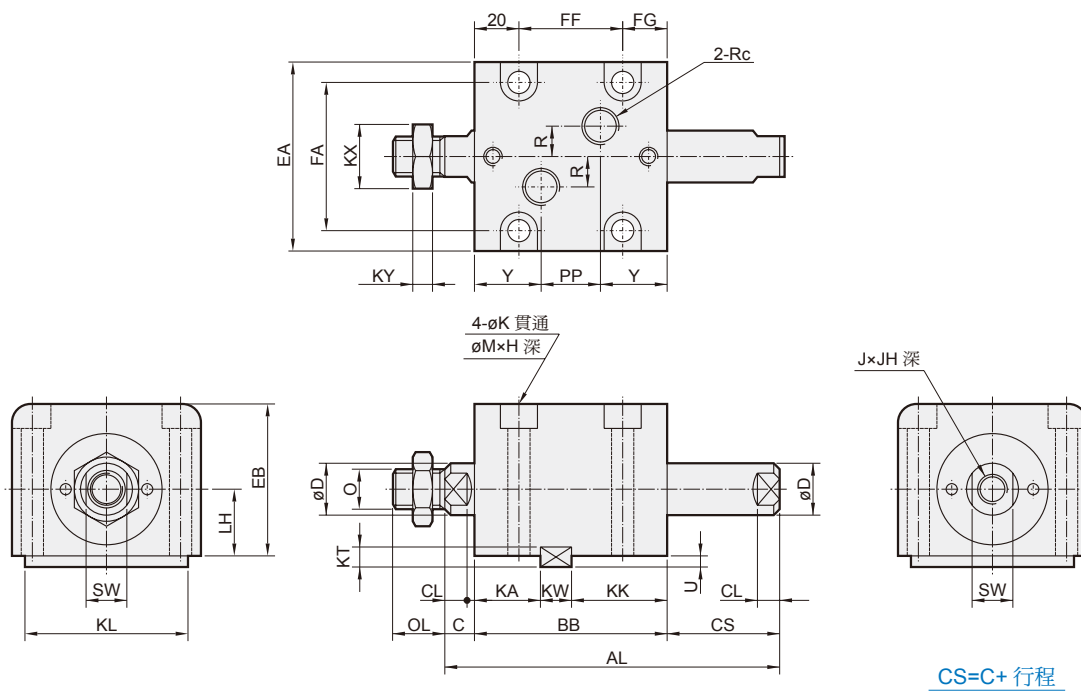

MHCQ-*D 外觀尺寸 – 雙軸型 $\phi 32 \sim \phi 63$



薄型油壓缸

Mindman

內徑	型式	MHCQ-RD / MHCQ-LD									
	代號 / 行程	5	10	15	20	25	30	35	40	45	50
$\phi 32$	AA	104	109	124	129	144	149	164	169	184	189
	BB	79	79	89	89	99	99	109	109	119	119
	CS	15	20	25	30	35	40	45	50	55	60
	FF	42	42	52	52	62	62	72	72	82	82
	KK	39	39	49	49	59	59	69	69	79	79
	PP	23	23	33	33	43	43	53	53	63	63
$\phi 40$	AA	105	110	125	130	145	150	165	170	185	190
	BB	80	80	90	90	100	100	110	110	120	120
	CS	15	20	25	30	35	40	45	50	55	60
	FF	42	42	52	52	62	62	72	72	82	82
	KK	40	40	50	50	60	60	70	70	80	80
	PP	24	24	34	34	44	44	54	54	64	64
$\phi 50$	AA	112	117	132	137	152	157	172	177	192	197
	BB	85	85	95	95	105	105	115	115	125	125
	CS	16	21	26	31	36	41	46	51	56	61
	FF	45	45	55	55	65	65	75	75	85	85
	KK	42	42	52	52	62	62	72	72	82	82
	PP	26	26	36	36	46	46	56	56	66	66
$\phi 63$	AA	123	128	143	148	163	168	183	188	203	208
	BB	92	92	102	102	112	112	122	122	132	132
	CS	18	23	28	33	38	43	48	53	58	63
	FF	52	52	62	62	72	72	82	82	92	92
	KK	45	45	55	55	65	65	75	75	85	85
	PP	30	30	40	40	50	50	60	60	70	70

代號 內徑	C	CL	D	EA	EB	FA	FG	H	J	JH	K	KA	KL	KT
$\phi 32$	10	7	20	70	56	56	17	9	M12×1.75	15	9	28	63	8
$\phi 40$	10	7	25	80	64	62	18	11	M16×2.0	20	11	28	70	8
$\phi 50$	11	8	30	94	74	74	20	13	M20×2.5	25	13	29	80	9
$\phi 63$	13	10	35	114	89	90	20	15	M27×3.0	35	15	31	100	10

代號 內徑	KW	KX	KY	LH	M	O	OL	PT	R	SW	U	Y
$\phi 32$	12	24	8	25	14	M16×1.5	25	Rc1/4	10	17	4.5	28
$\phi 40$	12	32	11	29	18	M22×1.5	30	Rc1/4	10	22	4.5	28
$\phi 50$	14	35	14	34	20	M26×1.5	35	Rc1/4	10	27	5	29.5
$\phi 63$	16	41	13	42	22	M30×1.5	40	Rc3/8	10	32	5.5	31

MHCB 外觀尺寸 – 可調行程 $\phi 32 \sim \phi 80$

薄型油壓缸

MHCB-DA

可調行程 25 mm

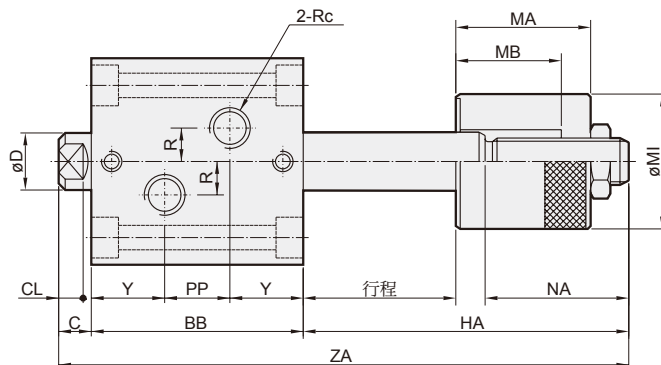
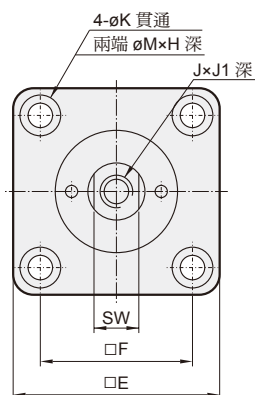

MHCB-ZDA

可調行程 25 mm

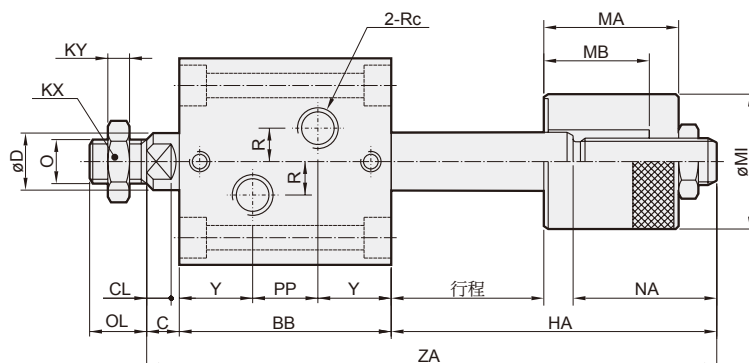
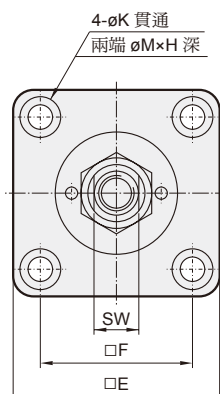

MHCB-DB

可調行程 50 mm

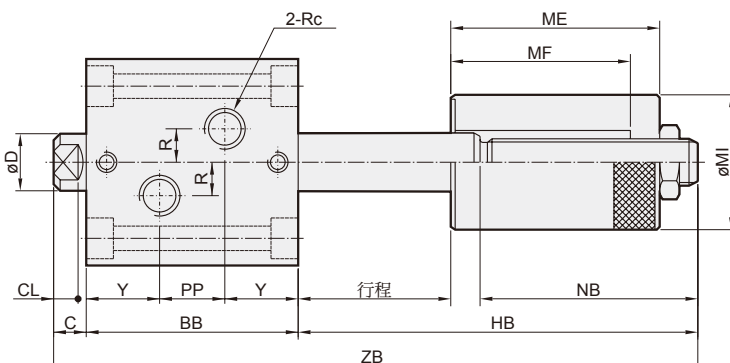
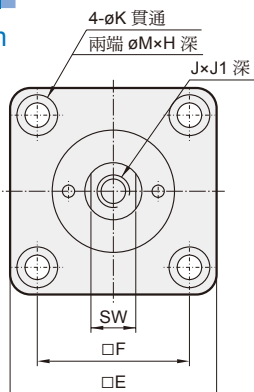

MHCB-ZDB

可調行程 50 mm

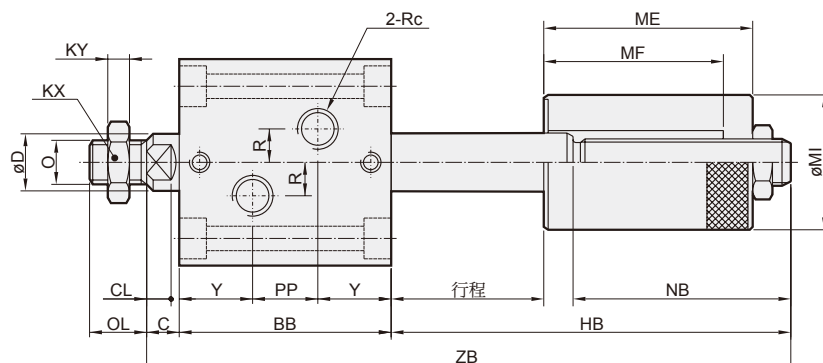
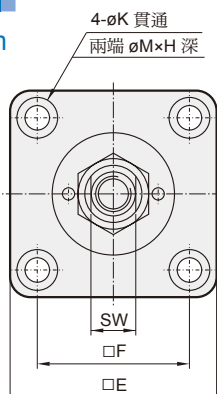

MHCB 外觀尺寸 – 可調行程 $\phi 32 \sim \phi 80$



薄型油壓缸

Mindman

內徑	型式	MHCB-DA / MHCB-ZDA														
	代號 / 行程	5	10	15	20	25	30	35	40	45	50	60	70	80	90	100
$\phi 32$	ZA	153	158	173	178	193	198	213	218	233	238	-	-	-	-	-
	BB	79	79	89	89	99	99	109	109	119	119	-	-	-	-	-
	PP	23	23	33	33	43	43	53	53	63	63	-	-	-	-	-
	HA	64	69	74	79	84	89	94	99	104	109	-	-	-	-	-
$\phi 40$	ZA	163	168	183	188	203	208	223	228	243	248	-	-	-	-	-
	BB	80	80	90	90	100	100	110	110	120	120	-	-	-	-	-
	PP	24	24	34	34	44	44	54	54	64	64	-	-	-	-	-
	HA	73	78	83	88	93	98	103	108	113	118	-	-	-	-	-
$\phi 50$	ZA	171	176	191	196	211	216	231	236	251	256	-	-	-	-	-
	BB	85	85	95	95	105	105	115	115	125	125	-	-	-	-	-
	PP	26	26	36	36	46	46	56	56	66	66	-	-	-	-	-
	HA	75	80	85	90	95	100	105	110	115	120	-	-	-	-	-
$\phi 63$	ZA	188	193	208	213	228	233	248	253	268	273	-	-	-	-	-
	BB	92	92	102	102	112	112	122	122	132	132	-	-	-	-	-
	PP	30	30	40	40	50	50	60	60	70	70	-	-	-	-	-
	HA	83	88	93	98	103	108	113	118	123	128	-	-	-	-	-
$\phi 80$	ZA	207	212	227	232	247	252	267	272	287	292	-	-	-	-	-
	BB	103	103	113	113	123	123	133	133	143	143	-	-	-	-	-
	PP	37	37	47	47	57	57	67	67	77	77	-	-	-	-	-
	HA	87	92	97	102	107	112	117	122	127	132	-	-	-	-	-

內徑	型式	MHCB-DB / MHCB-ZDB														
	代號 / 行程	5	10	15	20	25	30	35	40	45	50	60	70	80	90	100
$\phi 32$	ZB	178	183	198	203	218	223	238	243	258	263	-	-	-	-	-
	BB	79	79	89	89	99	99	109	109	119	119	-	-	-	-	-
	PP	23	23	33	33	43	43	53	53	63	63	-	-	-	-	-
	HB	89	94	99	104	109	114	119	124	129	134	-	-	-	-	-
$\phi 40$	ZB	188	193	208	213	228	233	248	253	268	273	-	-	-	-	-
	BB	80	80	90	90	100	100	110	110	120	120	-	-	-	-	-
	PP	24	24	34	34	44	44	54	54	64	64	-	-	-	-	-
	HB	98	103	108	113	118	123	128	133	138	143	-	-	-	-	-
$\phi 50$	ZB	196	201	216	221	236	241	256	261	276	281	-	-	-	-	-
	BB	85	85	95	95	105	105	115	115	125	125	-	-	-	-	-
	PP	26	26	36	36	46	46	56	56	66	66	-	-	-	-	-
	HB	100	105	110	115	120	125	130	135	140	145	-	-	-	-	-
$\phi 63$	ZB	213	218	233	238	253	258	273	278	293	298	-	-	-	-	-
	BB	92	92	102	102	112	112	122	122	132	132	-	-	-	-	-
	PP	30	30	40	40	50	50	60	60	70	70	-	-	-	-	-
	HB	108	113	118	123	128	133	138	143	148	153	-	-	-	-	-
$\phi 80$	ZB	232	237	252	257	272	277	292	297	312	317	-	-	-	-	-
	BB	103	103	113	113	123	123	133	133	143	143	-	-	-	-	-
	PP	37	37	47	47	57	57	67	67	77	77	-	-	-	-	-
	HB	112	117	122	127	132	137	142	147	152	157	-	-	-	-	-

代號 內徑	C	CL	D	E	F	H	J	J1	K	KX	KY	M	MI	MA
$\phi 32$	10	7	20	62	47	6.5	M12 \times 1.75	15	6.6	24	8	11	45	46
$\phi 40$	10	7	25	70	52	9	M16 \times 2.0	20	9	32	11	14	55	54
$\phi 50$	11	8	30	80	58	11	M20 \times 2.5	25	11	35	14	18	60	53
$\phi 63$	13	10	35	94	69	13	M27 \times 3.0	35	13	41	13	20	75	63
$\phi 80$	17	14	45	114	86	15	M30 \times 3.5	35	15	50	10	22	90	70

代號 內徑	MB	ME	MF	NA	NB	O	OL	PT	R	SW	Y
$\phi 32$	36	71	61	49	74	M16 \times 1.5	25	Rc1/4	10	17	28
$\phi 40$	36	79	61	58	83	M22 \times 1.5	30	Rc1/4	10	22	28
$\phi 50$	37	78	62	59	84	M26 \times 1.5	35	Rc1/4	10	27	29.5
$\phi 63$	39	88	64	65	90	M30 \times 1.5	40	Rc3/8	10	32	31
$\phi 80$	43	95	68	65	90	M39 \times 1.5	45	Rc3/8	15	41	33

MHCQ-DA 外觀尺寸 – 可調行程 $\phi 32 \sim \phi 63$

薄型油壓缸



MHCQ-DA

可調行程 25 mm

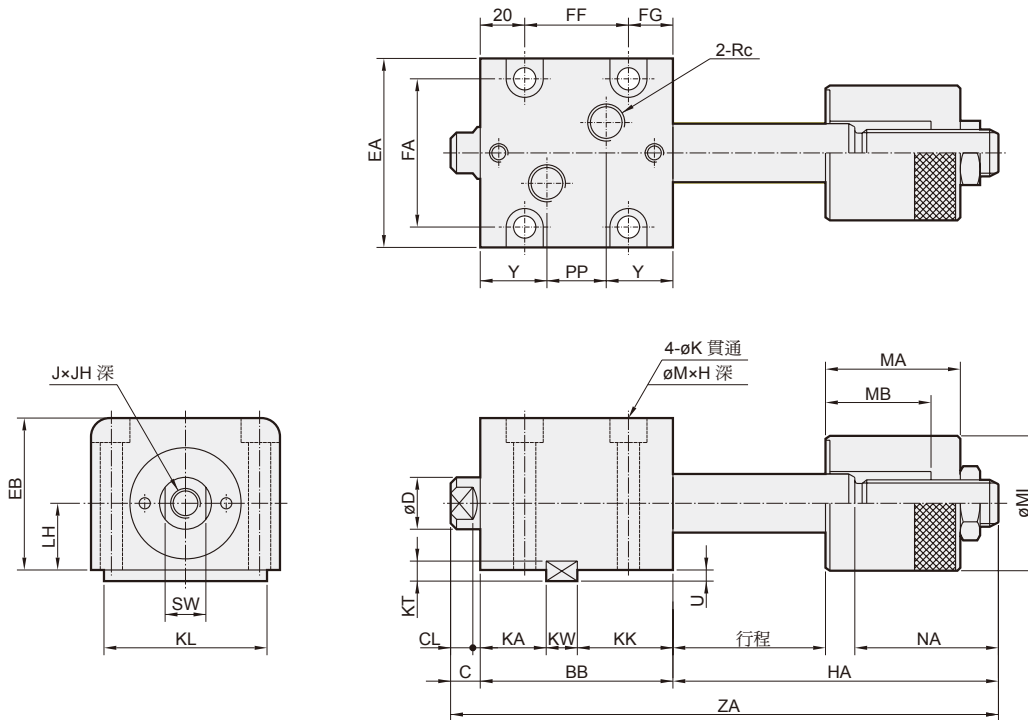

MHCQ-ZDA

可調行程 25 mm

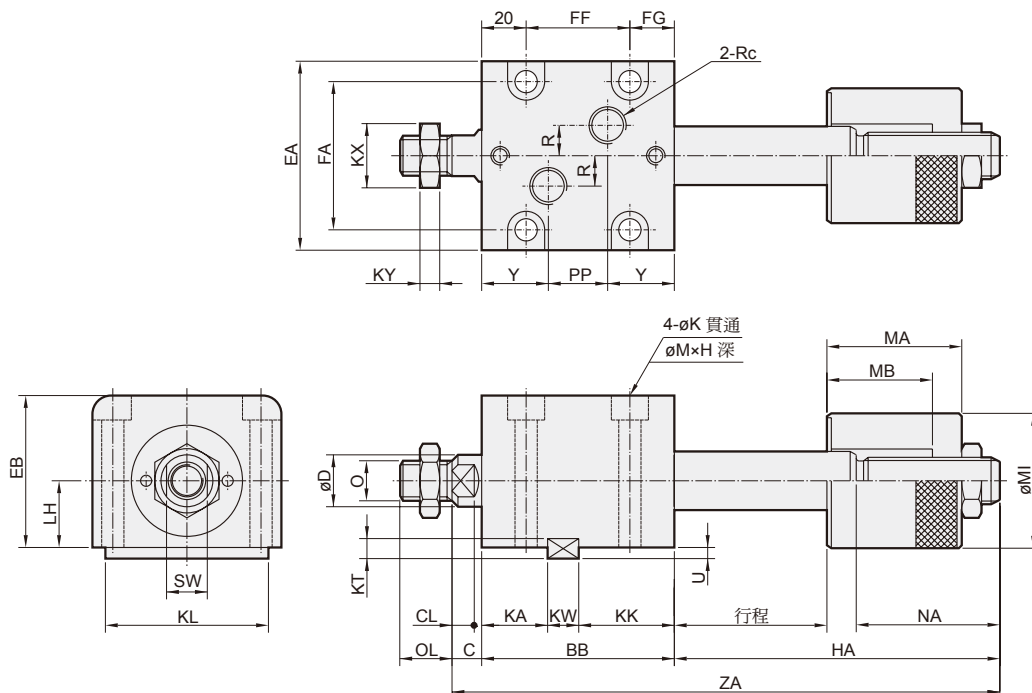

MHCQ-DA 外觀尺寸 – 可調行程 $\phi 32\sim\phi 63$



薄型油壓缸

Mindman

內徑	型式	MHCQ-DA / MHCQ-ZDA									
	代號 / 行程	5	10	15	20	25	30	35	40	45	50
ø32	ZA	153	158	173	178	193	198	213	218	233	238
	BB	79	79	89	89	99	99	109	109	119	119
	FF	42	42	52	52	62	62	72	72	82	82
	KK	39	39	49	49	59	59	69	69	79	79
	PP	23	23	33	33	43	43	53	53	63	63
	HA	64	69	74	79	84	89	94	99	104	109
ø40	ZA	163	168	183	188	203	208	223	228	243	248
	BB	80	80	90	90	100	100	110	110	120	120
	FF	42	42	52	52	62	62	72	72	82	82
	KK	40	40	50	50	60	60	70	70	80	80
	PP	24	24	34	34	44	44	54	54	64	64
	HA	73	78	83	88	93	98	103	108	113	118
ø50	ZA	171	176	191	196	211	216	231	236	251	256
	BB	85	85	95	95	105	105	115	115	125	125
	FF	45	45	55	55	65	65	75	75	85	85
	KK	42	42	52	52	62	62	72	72	82	82
	PP	26	26	36	36	46	46	56	56	66	66
	HA	75	80	85	90	95	100	105	110	115	120
ø63	ZA	188	193	208	213	228	233	248	253	268	273
	BB	92	92	102	102	112	112	122	122	132	132
	FF	52	52	62	62	72	72	82	82	92	92
	KK	45	45	55	55	65	65	75	75	85	85
	PP	30	30	40	40	50	50	60	60	70	70
	HA	83	88	93	98	103	108	113	118	123	128

代號 內徑	C	CL	D	EA	EB	FA	FG	H	J	JH	K	KA	KL	KT	KW
ø32	10	7	20	70	56	56	17	9	M12×1.75	15	9	28	63	8	12
ø40	10	7	25	80	64	62	18	11	M16×2.0	20	11	28	70	8	12
ø50	11	8	30	94	74	74	20	13	M20×2.5	25	13	29	80	9	14
ø63	13	10	35	114	89	90	20	15	M27×3.0	35	15	31	100	10	16

代號 內徑	KX	KY	LH	M	MI	MA	MB	NA	O	OL	PT	R	SW	U	Y
ø32	24	8	25	14	45	46	36	49	M16×1.5	25	Rc1/4	10	17	4.5	28
ø40	32	11	29	18	55	54	36	58	M22×1.5	30	Rc1/4	10	22	4.5	28
ø50	35	14	34	20	60	53	37	59	M26×1.5	35	Rc1/4	10	27	5	29.5
ø63	41	13	42	22	75	63	39	65	M30×1.5	40	Rc3/8	10	32	5.5	31

MHCQ-DB 外觀尺寸 - 可調行程 $\phi 32 \sim \phi 63$



薄型油壓缸

MHCQ-DB

可調行程 50 mm

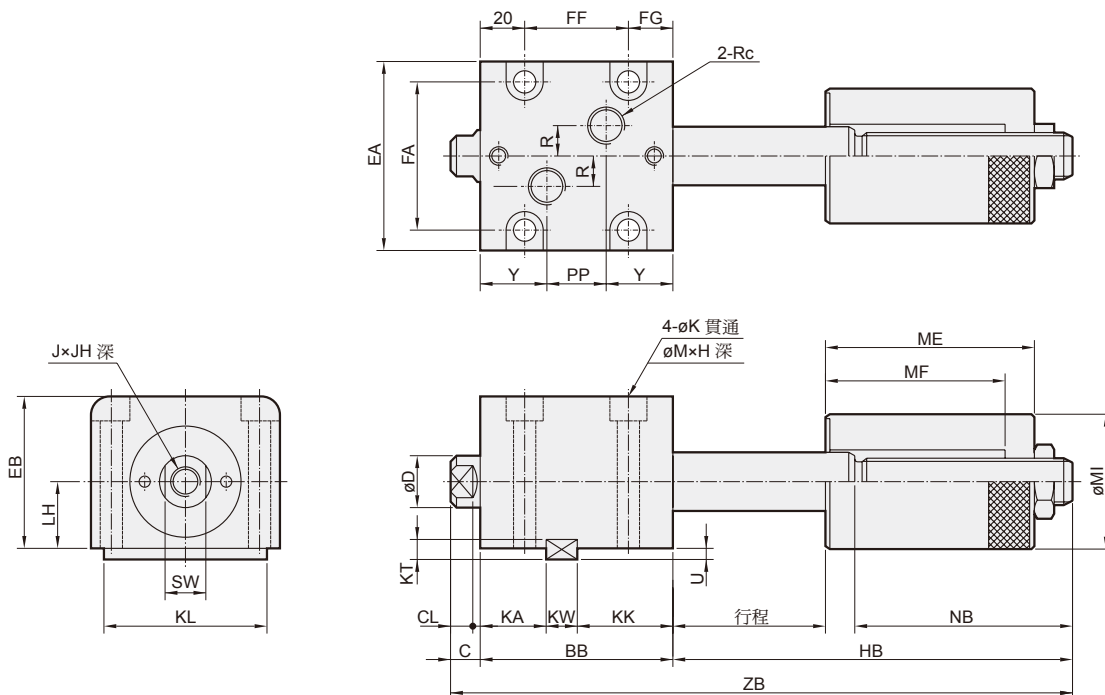

MHCQ-ZDB

可調行程 50 mm

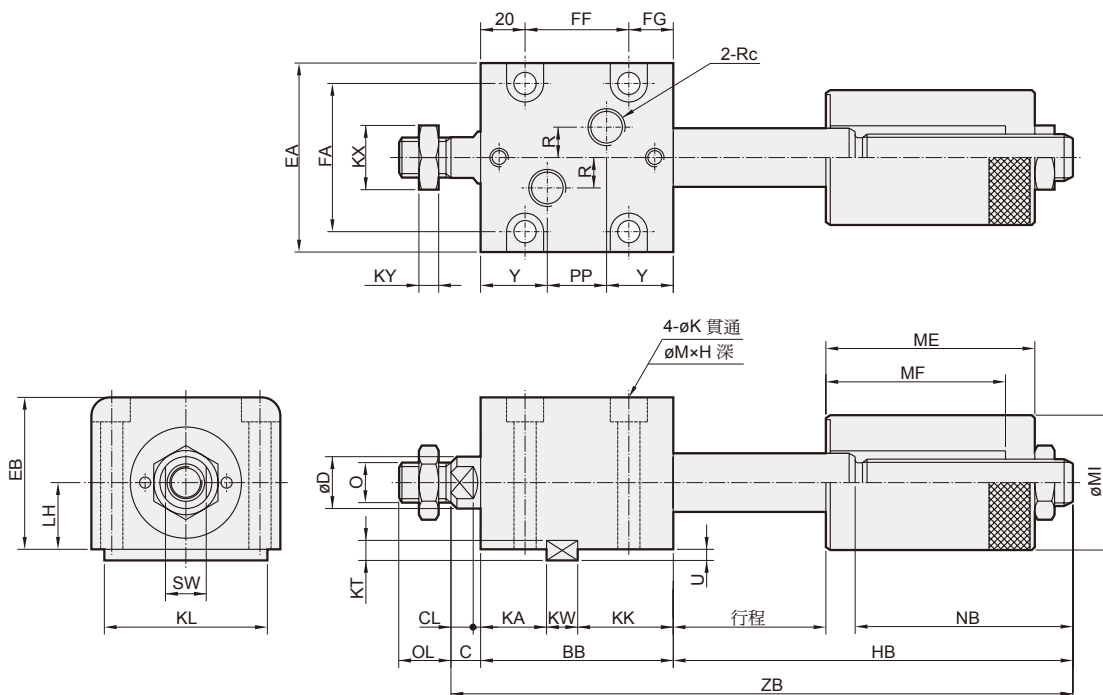

MHCQ-DB 外觀尺寸 – 可調行程 $\phi 32 \sim \phi 63$



薄型油壓缸

Mindman

內徑	型式	MHCQ-DB / MHCQ-ZDB									
	代號 / 行程	5	10	15	20	25	30	35	40	45	50
ø32	ZB	178	183	198	203	218	223	238	243	258	263
	BB	79	79	89	89	99	99	109	109	119	119
	FF	42	42	52	52	62	62	72	72	82	82
	KK	39	39	49	49	59	59	69	69	79	79
	PP	23	23	33	33	43	43	53	53	63	63
	HB	89	94	99	104	109	114	119	124	129	134
ø40	ZB	188	193	208	213	228	233	248	253	268	273
	BB	80	80	90	90	100	100	110	110	120	120
	FF	42	42	52	52	62	62	72	72	82	82
	KK	40	40	50	50	60	60	70	70	80	80
	PP	24	24	34	34	44	44	54	54	64	64
	HB	98	103	108	113	118	123	128	133	138	143
ø50	ZB	196	201	216	221	236	241	256	261	276	281
	BB	85	85	95	95	105	105	115	115	125	125
	FF	45	45	55	55	65	65	75	75	85	85
	KK	42	42	52	52	62	62	72	72	82	82
	PP	26	26	36	36	46	46	56	56	66	66
	HB	100	105	110	115	120	125	130	135	140	145
ø63	ZB	213	218	233	238	253	258	273	278	293	298
	BB	92	92	102	102	112	112	122	122	132	132
	FF	52	52	62	62	72	72	82	82	92	92
	KK	45	45	55	55	65	65	75	75	85	85
	PP	30	30	40	40	50	50	60	60	70	70
	HB	108	113	118	123	128	133	138	143	148	153

代號 內徑	C	CL	D	EA	EB	FA	FG	H	J	JH	K	KA	KL	KT	KW
ø32	10	7	20	70	56	56	17	9	M12×1.75	15	9	28	63	8	12
ø40	10	7	25	80	64	62	18	11	M16×2.0	20	11	28	70	8	12
ø50	11	8	30	94	74	74	20	13	M20×2.5	25	13	29	80	9	14
ø63	13	10	35	114	89	90	20	15	M27×3.0	35	15	31	100	10	16

代號 內徑	KX	KY	LH	M	MI	ME	MF	NB	O	OL	PT	R	SW	U	Y
ø32	24	8	25	14	45	71	61	74	M16×1.5	25	Rc1/4	10	17	4.5	28
ø40	32	11	29	18	55	79	61	83	M22×1.5	30	Rc1/4	10	22	4.5	28
ø50	35	14	34	20	60	78	62	84	M26×1.5	35	Rc1/4	10	27	5	29.5
ø63	41	13	42	22	75	88	64	90	M30×1.5	40	Rc3/8	10	32	5.5	31